

HERMOSA TOWN BOARD
TUESDAY, MAY 16, 2023
REGULAR MEETING @ 6.00pm

- 1) **ROLL CALL:**
 - A. BOT Roll Call: Henrichsen, Holsworth, Kramer, Schumack
 - B. Acknowledgement of other Attendees
 - C. Pledge of Allegiance to be led by Holsworth

- 2) **CALL FOR CHANGES:**
 - A. Review of current agenda items
 - B. Motion to accept the agenda as presented/amended

- 3) **CONSENT CALENDAR:**
 - A. Approval of the May 2nd, 2023, Regular meeting minutes

- 4) **CONFLICT OF INTEREST DECLARATION**

- 5) **PUBLIC HEARING**

2023-24 Malt beverage & SD Farm wine renewals

 1. **Pop's Grocery**, 30 N. Ferguson Street, G & G Sub - Lot 1 (Formerly Outlot E) IN SW4SE4 Sec 29 T2 R8, Hermosa, Custer County, South Dakota, 57744; Retail (on-off sale) Malt Beverage
 2. **Corner Pantry Travel Center** – Outlot M of J&B Subdivision Section 30, T2, R8, Custer County, South Dakota, 57744; Retail (on-off sale) Malt Beverage & SD Farm Wine
 3. **Hermosa Community Center LLC**, Lots 23&24, Block 5, Town of Hermosa, Section 32, T2S, R8E, BHM, Custer County, South Dakota, 57744; Retail (on-off sale) Malt Beverage

- 6) **CLAIMS:**
 - A. Review payroll and claims
 - B. Motion to approve the claims as presented/amended

- 7) **LAW ENFORCEMENT/ ABATEMENTS/COMPLAINTS:**
 - A. Committee report
 - B. Custer County Log
 - C. Abatements
Properties, Dumpster

- 8) **LEGAL:**
 - A. Permit #2022-09 for 194 Fairgrounds Place road
 - B. Initiative petition-Term limits

- 9) **ENGINEER:**
 - A. Water Rehab Project (WRT System)
 - B. Hermosa Sidewalk Project
 - C. Sewer Project (Lagoon design & expansion)
 - D. Water/Sewer Facility Plans
 - Resolution(s) review
 - DANR Award
 - Bruels Email
 - E. Black Hills Council of Local Governments
 - F. Town of Hermosa Water and Sewer Extension Project
 - G. Hermosa Hills Drainage
 - Town accept Marie Street-pending
 - Town accept Walter Street-pending
 - H. Whitney Street Drainage
 - SDARWS Report, Pending technician assistance, update on timeline
 - Camera drainage/awaiting meeting with school board
 - I. Roy's Drive In Sewer Line
 - Pending Roy's response
 - J. Facility Plan for Booster, Water Meters
 - Possibly to add to USDA-pending
 - K. Rural Development
 - Application pending

- 10) **PLANNING & ZONING**
A. Review P&Z meeting minutes from May 9th, 2023, meeting
B. Permit 2022-25 - REVISED- Digging/ROW-Sewer Connection- Parcels 009318 & 009319
C. 2023-06 – Commercial Remodeling Permit Application – 250 Main St. – Storage Loft – pending
D. 2023-15 – Informational Permit – 27 N. 4th St. – Pour 10x16 cement deck.
E. Request from Hermosa Connects, Inc. to waive \$25.00 vendor fees for June 24, 2023 Vendor Fair & Farmers Market.
- 11) **PUBLIC WORKS**
A. Committee Report
B. Streets, Street Light Repairs, Water & Sewer Department Updates
Trustee report on town lighting needs
C. Agreement for performance of services of public works and town maintenance
D. Chuck Irvine training expenses
- 12) **FINANCE OFFICE:**
A. Monthly financials.
B. Department updates
C. New meter costs
D. SDPAA renewal
E. Budget training – Pierre, June 21st
F. Mosquito control grant-Monte Waltman-VanDiest company
G. Transportation economic development grants
H. Grant research
I. Certificate of deposit – ARPA funds
- 13) **OLD BUSINESS:**
A. Annexation: Gumbo Lilly, Fairgrounds Place, McDermard Street
B. Town Sign, pending
C. Town Office: Deck Staining, pending
D. Library: Deck Staining, pending
E. Hermosa Connects
- 14) **NEW BUSINESS:**
A. Boundary updates, U.S Census Bureau
B. Walter street maintenance – move stop sign request, add gravel
- 15) **ITEMS FROM CITIZENS:** No action will be taken (3-minute time limit per speaker)
Meetings of the Board of Trustees are open to the public. The audience may be allowed to comment on specific agenda items during the time allotted on the agenda for those items, according to established procedures of the Board. This is a time for members of the public to express concerns or discuss issues having relevance to the town. Anyone wishing to address the Town Board during this time shall be asked to identify themselves. The number of presentations and time allotted to individuals may be limited by the board president and individuals shall refrain from discussing personalities. The president at his discretion, may recognize patrons at other times during the board meeting. No action will be taken by the board on any issue related without being first placed on a future agenda, by the board, to allow for proper notice.
- 16) **TRUSTEE INPUT:**
- 17) **EXECUTIVE SESSION:**
A. Motion to enter Executive Session allowable by SDCL 1-25-2.1 – Legal/Personnel/Contract
B. Motion to exit out of Executive Session
C. Motions resulting from Executive Session
- 18) **ADJOURN:** Motion by _____; Second by _____ to adjourn the meeting at _____ PM.

3 A.

**HERMOSA TOWN BOARD
TUESDAY, MAY 2, 2023
REGULAR MEETING @ 6.00pm**

ROLL CALL: Holsworth called the meeting to order on Tuesday, May 2nd at 6.00 pm with the following members present: Henrichsen, Holsworth, Kramer, Schumack. Also present: Chuck Ferguson, Mitch Johnson(absent), law enforcement and citizens. Pledge of Allegiance led by Dan Holsworth.

CALL FOR CHANGES: Motion made, seconded to approve agenda as presented; Vote: all ayes, motion carried.

CONSENT CALENDAR: Motion made, seconded to approve April 18th, 2023 regular meeting minutes as presented; Vote: all ayes, motion carried.

CONFLICT OF INTEREST DECLARATION: None

CLAIMS: A & B Business equipment: Monthly printer/fax fee \$580.25; Black Hills electric Coop: Utilities-Electric 04/2023 \$3,029.85; Chuck Ferguson: Monthly agreement 04/2023 \$2,600.00; Chuck Irvine: Change lightbulb at 250 Main \$10.00, Training expense April 2023 \$120.00; Dakota Supply Group: Booster pump \$1,141.92; Hawkins, Inc.: Drinking water treatment chem. \$197.25; Metering & Technology solutions: Meters, installation kits \$1,553.01; Miller Construction: 3X 22 Ton Base course \$1,884.96; Nelson's Oil & Gas Inc.: Propane-city well \$321.51; Pioneer Bank & Trust: Stamps, Water \$331.03, 2 signature account fee \$25.00; Summit Signs and Supply Inc.: Fire extinguisher annual insp. \$233.00; US Bank: N Sewer TIF-Principal/final \$68,981.35; Accounts Payable Total: \$81,009.13. Utility Deposit Refund: Kathy Brewer \$97.15, Chasen Cole \$92.93, Travis & Kelly Degrote \$4.43, Andrea Paulson \$0.20, Leslee Woodyard \$25.20; UB Deposit Refund Total \$219.91. Payroll related: Legislative \$692.62, Financial administration \$2,011.02, Gen. Gov't buildings \$96.97, Water \$329.94, Sewer \$157.45, Promoting City/ BBB \$52.48, EFTPS-Electronic Federal Tax \$850.41, Health Pool of SD FO & Admin single health/life 05/23 \$1,835.74, SDRS \$724.30. Total Payroll Paid: \$6,750.93. CLAIMS TOTAL: \$87,979.97. By Fund: General \$10,399.25, BBB Gross receipt tax \$300.73, Debt Service \$68,981.35, Water \$6,634.74, Sewer \$1,663.90. Motion made, seconded to approve claims list as amended; Vote: all ayes motion carried.

LAW ENFORCEMENT/ ABATEMENTS/COMPLAINTS: Custer County Log will be included in the next BOT meeting packet. Letter was sent to County Sheriff's office asking to possibly provide more specific information on how many calls throughout the month are addressed outside and within Town limits. They are looking into this request and will work with the town on this matter. Town's yard waste dumpster sign and camera system updated.

LEGAL: Permit #2022-09 for 194 Fairgrounds Place Road – pending

ENGINEER: Water Rehab Project (WRT System)- pending. Hermosa Sidewalk Project-pending. Sewer Project (Lagoon design & expansion) - awaiting design approval. Water/Sewer Facility Plans and Black Hills Council of Local Governments-pending. Town of Hermosa water and sewer extension project-pending, Hermosa Hills drainage-awaiting final walk-through, after the light is installed on Walter street and gravel issues addressed. Whitney street drainage-after all the research and working on various issues, Town's water consumption report for April was only at 1% loss, will continue monitoring the situation and work with the school on this matter. Roy's drive-in – Mitch Johnson sent a letter to Mr. Ortner, regarding Roy's Drive-In connection to the sewer system, response received. Will request pumping records to assure proper waste disposal. Facility plans for booster, water meters and Rural development - pending.

PLANNING & ZONING: Review of April 25th, 2023, P&Z meeting minutes. Permit 2022-25-Digging/Row- pending. 2023-06-commercial remodeling permit application – pending. Temporary sign permit application-no permit needed, only informational, reviewed and agreed on by P&Z and BOT boards. Motion made, seconded to approve the new address: 850 Marie street for Parcel #015391; Vote: all ayes, motion carried. Permit #2023-14 – Informational permit – park models at Southern Hills RV park review by the board, no motion needed. Motion made, seconded to remove items 9) D. E. & F. from the agenda; Vote: all ayes, motion carried.

PUBLIC WORKS: Update report by Chuck Ferguson: Streets maintenance – ongoing process, streetlights-in good shape, water – samples taken for testing, consumption report shows only 1% of water loss for the month of April, sewer – one of the pumps had to be repaired. The agreement for performance of services of public works and town maintenance - pending. Chuck Irvine training expense of \$120 for attending the classes included in the claims. 72 Fairgrounds place – bill paid in full, will keep monitoring. Motion made, seconded to not charge for the water meter, which was replaced in March, since the old one was not damaged and in good working condition and has been reused as a garden meter; Vote: 3 ayes, 1 Nay, motion carried. Motion made, seconded to remove items 10) E. & F. from the agenda; Vote: all ayes, motion carried.

FINANCE OFFICE: Monthly financials –pending. Department updates: Town of Hermosa selected as a recipient of \$2500.00 traffic control Grant. Election ballot sample presented in the packet. Monte Waltman attended mosquito workshop on 05/02/23 in Rapid City, equipment checked. FO going to gather information to apply for mosquito grant. N Sewer TIF loan paid off and is at \$0 balance.

Motion made, seconded to increase amount limit before delinquent/shut off notice is issued to \$230.00; Vote: all ayes, motion carried.
Motion made, seconded to remove items 11) C. & D. from the agenda; Vote: all ayes, motion carried.

OLD BUSINESS: Annexation: Gumbo Lilly, Fairgrounds Place, McDermand Street-pending. Town Sign- pending. Town Office and Library deck Staining-pending. Hermosa connects- Farmer's Market & Vendor Fair scheduled for June 24th, so far 31 vendors signed up to attend. Vendor permit fees will be discussed at the following P&Z and BOT meetings. Information about Hermosa Connects group and upcoming events can be found at www.hermosaconnects.com website as well as Facebook page. Next meeting is scheduled for May 9th 2023 @8.30am at the Coffee shop.

NEW BUSINESS: Boundary updates – pending. Walter street maintenance – stop sign to be moved this week, additional gravel pending. Malt beverage renewals – pending. Letter sent to Mr. Naugle to inform school staff about coming duplex construction on 5th street so parking will not be an option on that street during that time. Motion made, seconded to remove item 13) D. from the agenda; Vote: all ayes, motion carried.

ITEMS FROM CITIZENS: Audience had input.

TRUSTEE INPUT: Appreciate all the work done. Good information.

EXECUTIVE SESSION: no executive session.

ADJOURN: Motion made, seconded to adjourn the meeting at 7.06 PM; Vote: all ayes, motion carried.

ATTEST:

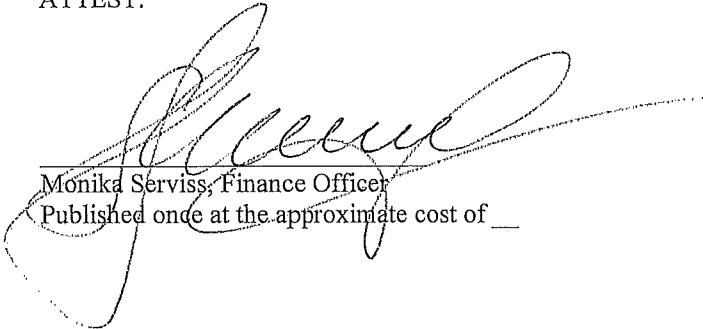

Monika Serviss, Finance Officer

Published once at the approximate cost of _

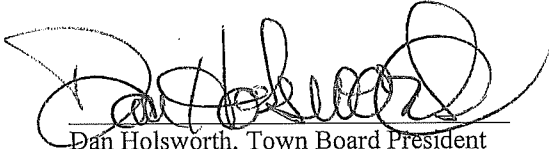

Dan Holsworth, Town Board President

Date Received _____
Date Issued _____

2023-2024

License No. RB-25133

5 1.

Uniform Alcoholic Beverage License Application

A. Corporation, LLC, or Sole Proprietor Name and Mailing Address

B. Doing Business As Name and Physical Address

DANIEL C MARTIN
30 N FERGUSON ST
HERMOSA, SD 57744-2306

Lic # RB-25133
POP'S GROCERY
30 N FERGUSON ST
HERMOSA, SD 57744-2306

Owner's Telephone#: (605) 255-5977

Business Telephone #: (605) 255-5977

C. Indicate the class of license being applied for (submit separate application for each class of license).

Place of business is located in a municipality? Yes [] No

- Retail (on-sale) Liquor
- Retail (on-sale) Liquor - Restaurant
- Convention Center (on-sale) Liquor
- Package (off-sale) Liquor
- Retail (on-off sale) Wine and Cider
- Retail (on-off sale) Malt Beverage & SD Farm Wine
- Package Delivery
- Hunting Preserve
- Other _____

County: CUSTER

Do you own or lease [] this property? (Check one)

Are real property taxes paid to date? Yes [] No

Are you of good moral character having never been convicted of a felony? [] Yes No

D. Legal description of licensed premise:

Is this License in active use? Yes [] No

Do you or any officers, directors, partners, or stockholders hold any other alcohol retail, manufacturing, or wholesaler licenses?
[] Yes No **If Yes, please list on the back page**

E. State Sales Tax Number: 1014-0255-ST

F. New license? _____ Transfer? (\$150) _____ Re-issuance? _____

G. CERTIFICATE The undersigned applicant certifies under the penalties of perjury that all statements herein are true and correct; that the said applicant complies with all of the statutory requirements for the class of license being applied for and in addition agrees to permit agents of the Department of Revenue access to the licensed premises and records as provided in SDCL 35-2-2.1, and agrees this application shall constitute a contract between applicant and the State of South Dakota entitling the same or any peace officers to inspect the premises, books and records at any time for the purpose of enforcing the provisions of Title 35 SDCL, as amended.

Date MM/11/2023 Print Name DANIEL C MARTIN Signature Daniel C Martin

H. APPROVAL OF LOCAL GOVERNING BODY- Notice of hearing was published _____ . Public hearing on the application was held _____, not less than SEVEN (7) days after official publication. The governing body by majority vote recommends the approval and granting of this license and certifies that requirements as to location and suitability of premises and applicant have been reviewed and conform to the requirements of local and South Dakota law.

For Local Government Use

Renewal - no public hearing held
Amount of fee collected with application \$ _____
Amount of fee retained \$ _____
Forwarded with application \$ _____

(Seal) _____
Mayor or Chairman

If disapproved, endorse reason thereon and return to applicant

Please complete reverse side

52.

Date Received

Date Issued

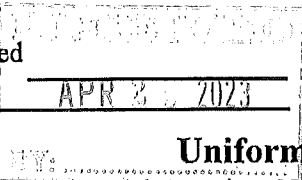

2023-2024

License No. RB-2776

Uniform Alcoholic Beverage License Application

A. Corporation, LLC, or Sole Proprietor Name and Mailing Address

B. Doing Business As Name and Physical Address

M G OIL COMPANY
PO BOX 1006
RAPID CITY, SD 57709-1006

Lic # RB-2776
CORNER PANTRY TRAVEL CENTER
25 N HEARTLAND EXP #101
HERMOSA, SD 57744

Owner's Telephone#: (605) 342-0527

Business Telephone #: 605-255-4555

C. Indicate the class of license being applied for (submit separate application for each class of license).

- Retail (on-sale) Liquor
Retail (on-sale) Liquor - Restaurant
Convention Center (on-sale) Liquor
Package (off-sale) Liquor
Retail (on-off sale) Wine and Cider
[X] Retail (on-off sale) Malt Beverage & SD Farm Wine
Package Delivery
Hunting Preserve
Other

Place of business is located in a municipality? [X] Yes [] No

County: Custer

Do you own [X] or lease [] this property? (Check one)

Are real property taxes paid to date? [X] Yes [] No

Are you of good moral character having never been convicted of a felony? [X] Yes [] No

D. Legal description of licensed premise:

Out lot M of J&B Subdivision Section 30, T2, R8, Custer County, South Dakota

Is this License in active use? [X] Yes [] No

Do you or any officers, directors, partners, or stockholders hold any other alcohol retail, manufacturing, or wholesaler licenses? [X] Yes [] No If Yes, please list on the back page

E. State Sales Tax Number: 1014-8577-ST

F. New license? ___ Transfer? (\$150) ___ Re-issuance? X

G. CERTIFICATE The undersigned applicant certifies under the penalties of perjury that all statements herein are true and correct; that the said applicant complies with all of the statutory requirements for the class of license being applied for and in addition agrees to permit agents of the Department of Revenue access to the licensed premises and records as provided in SDCL 35-2-2.1, and agrees this application shall constitute a contract between applicant and the State of South Dakota entitling the same or any peace officers to inspect the premises, books and records at any time for the purpose of enforcing the provisions of Title 35 SDCL, as amended.

Date 4/19/2023 Print Name Troy Erickson Signature [Signature]

H. APPROVAL OF LOCAL GOVERNING BODY- Notice of hearing was published [] Public hearing on the application was held [] not less than SEVEN (7) days after official publication. The governing body by majority vote recommends the approval and granting of this license and certifies that requirements as to location and suitability of premises and applicant have been reviewed and conform to the requirements of local and South Dakota law.

For Local Government Use

Renewal - no public hearing held []
Amount of fee collected with application \$
Amount of fee retained \$
Forwarded with application \$

(Seal) _____ Mayor or Chairman

If disapproved, endorse reason thereon and return to applicant

Please complete reverse side

Date Received _____
Date Issued _____

2023-2024

License No. 53 RB-27834

Uniform Alcoholic Beverage License Application

A. Corporation, LLC, or Sole Proprietor Name and Mailing Address

B. Doing Business As Name and Physical Address

HERMOSA COMMUNITY CENTER LLC
3204 LYNNWOOD AVE
RAPID CITY, SD 57701

Lic # RB-27834
HERMOSA COMMUNITY CENTER
122 VILAS STREET
HERMOSA, SD 57744

Owner's Telephone#: _____

Business Telephone #: (605) 639-0024

C. Indicate the class of license being applied for (submit separate application for each class of license).

Place of business is located in a municipality? [] Yes [] No

- Retail (on-sale) Liquor
- Retail (on-sale) Liquor - Restaurant
- Convention Center (on-sale) Liquor
- Package (off-sale) Liquor
- Retail (on-off sale) Wine and Cider
- Retail (on-off sale) Malt Beverage & SD Farm Wine
- Package Delivery
- Hunting Preserve
- Other _____

County: Custer

Do you own or lease [] this property? (Check one)

Are real property taxes paid to date? Yes [] No

Are you of good moral character having never been convicted of a felony? Yes [] No

D. Legal description of licensed premise:

Lots 23 & 24 Blocks Town of Hermosa
Section 32, T2S, R8E, B4M

Is this License in active use? Yes [] No

Do you or any officers, directors, partners, or stockholders hold any other alcohol retail, manufacturing, or wholesaler licenses?
[] Yes No If Yes, please list on the back page

E. State Sales Tax Number: 1037-4462-ST

F. New license? _____ Transfer? (\$150) _____ Re-issuance?

G. CERTIFICATE The undersigned applicant certifies under the penalties of perjury that all statements herein are true and correct; that the said applicant complies with all of the statutory requirements for the class of license being applied for and in addition agrees to permit agents of the Department of Revenue access to the licensed premises and records as provided in SDCL 35-2-2.1, and agrees this application shall constitute a contract between applicant and the State of South Dakota entitling the same or any peace officers to inspect the premises, books and records at any time for the purpose of enforcing the provisions of Title 35 SDCL, as amended.

Date 5-5-23 Print Name Lane Brengle Signature [Signature]

H. APPROVAL OF LOCAL GOVERNING BODY- Notice of hearing was published _____ . Public hearing on the application was held _____, not less than SEVEN (7) days after official publication. The governing body by majority vote recommends the approval and granting of this license and certifies that requirements as to location and suitability of premises and applicant have been reviewed and conform to the requirements of local and South Dakota law.

For Local Government Use

Renewal - no public hearing held
Amount of fee collected with application \$ _____
Amount of fee retained \$ _____
Forwarded with application \$ _____

(Seal) _____
Mayor or Chairman

If disapproved, endorse reason thereon and return to applicant

Please complete reverse side

6 A.

Claims for approval 05-16-2023

VENDOR	REFERENCE	AMOUNT
Custer County sheriff	Law enforcement contract/911 dispatch	\$ 8,666.67
Chuck Ferguson	Pull pump #1 & #2	\$ 700.00
Dakota Supply Group	Booster bushings,adapters, check valves,gaskets	\$ 81.40
Golden West Technologies	Monthly service-May23	\$ 563.50
Johnson Law Office	Legal advise,Mr.Styles e-mails	\$ 799.00
Metering & Technology solutions	Meters & meter supplies	\$ 3,519.48
Mt. Rushmore Telephone	Phone/Internet 12986289	\$ 255.73
Northwest pipe fittings Inc.	water lids,brass screws,adapt.	\$ 247.90
ODP Business solutions LLC	Paper(White&Color)	\$ 192.73
Pioneer Bank & Trust	Bank charge for 2 signat.acct.	\$ 25.00
Ruarl development	RD1 loan-May interest/principal	\$ 1,278.00
Ruarl development	RD2 loan-May interest/principal	\$ 417.00
Ruarl development	RD3 loan-May interest/principal	\$ 222.00
Sanders Sanitation	MONTHLY SANITATION SERV 04/23	\$ 4,376.02
SD Department of Revenue	Sales tax Mar/Apr 2023	\$ 570.46
SD Municipal League	FO school registration fee	\$ 75.00
Southern Hills Publishing	Publishing/Legal notices 04/23	\$ 195.93
Summit fire protection	Fire extinguisher annual insp.	\$ 233.00
Technichem, Inc.	25 lb Sludgebugs lagoon blend	\$ 359.10
US BANK	SRF May interest/principal	\$ 1,493.23
Vanda Belt	Lysol cleaner	\$ 16.52
Accounts Payable Total		\$ 24,287.67
Payroll related		
Total Paid On: 5/15/23	Financial administration	\$ 1,939.97
	Water	\$ 261.60
	Sewer	\$ 156.96
	Promoting City/ BBB	\$ 52.32
EFTPS-Electronic Federal Tax	FED/FICA TAX	\$ 609.35
Payroll Total		\$ 3,020.20
***** REPORT TOTAL *****		
GENERAL		\$ 18,257.40
BBB GROSS RECIPITS TAX		\$ 68.43
WATER		\$ 8,098.15
SEWER		\$ 883.89
TOTAL FUNDS		\$ 27,307.87



CUSTER COUNTY SHERIFF'S OFFICE
 SHERIFF MARTY MECHALEY
 420 MT RUSHMORE ROAD, CUSTER, SOUTH DAKOTA, 57730
 PHONE: (605) 673-8146 FAX: (605)673-8154



Hermosa - CFS's

Printed on May 2, 2023

CFS Date/Time	CFS #	Case Number	Code	Code : Description	Zone
04/01/23 06:00:04	CFS2303105		EXT	EXT : Extra Patrol	HERMOSA
04/01/23 12:35:00	CFS2303111		911M	911M : 911 Misdia	HERMOSA
04/01/23 22:15:57	CFS2303124		EXT	EXT : Extra Patrol	HERMOSA
04/03/23 06:03:10	CFS2303150		EXT	EXT : Extra Patrol	HERMOSA
04/03/23 07:35:15	CFS2303151		SPATROL	SPATROL : School Patrol	HERMOSA
04/03/23 12:00:06	CFS2303161		WILDLIFE	WILDLIFE : Wildlife	HERMOSA
04/03/23 15:21:38	CFS2303166		SPATROL	SPATROL : School Patrol	HERMOSA
04/03/23 19:55:00	CFS2303175		EXT	EXT : Extra Patrol	HERMOSA
04/04/23 08:40:51	CFS2303188		EXT	EXT : Extra Patrol	HERMOSA
04/04/23 14:09:55	CFS2303194		VEHABND	VEHABND : Abandoned	HERMOSA
04/04/23 14:54:55	CFS2303197		EXT	EXT : Extra Patrol	HERMOSA
04/04/23 19:21:00	CFS2303201		EXT	EXT : Extra Patrol	HERMOSA
04/05/23 09:24:21	CFS2303206		SPATROL	SPATROL : School Patrol	HERMOSA
04/05/23 09:44:12	CFS2303207		911A	911A : 911 Abandoned	HERMOSA

7 B.

CFS Date/Time	CFS #	Case Number	Code	Code : Description	Zone
04/05/23 15:59:41	CFS2303221		THREATS	THREATS : Threats	HERMOSA
04/05/23 19:35:29	CFS2303224	2023-00152	CIT	CIT : Citizen Assist	HERMOSA
04/05/23 20:48:02	CFS2303226	2023-00151	DRUNK	DRUNK : Drunkenness	HERMOSA
04/06/23 15:42:21	CFS2303237	2023-00155	SHOPLIFT	SHOPLIFT : Shoplifting	HERMOSA
04/06/23 16:47:22	CFS2303239		CIT	CIT : Citizen Assist	HERMOSA
04/06/23 17:22:15	CFS2303241		VEHSTLN	VEHSTLN : Stolen Vehicle	HERMOSA
04/06/23 18:51:54	CFS2303242		EXT	EXT : Extra Patrol	HERMOSA
04/06/23 19:00:45	CFS2303243		CONCIT	CONCIT : Concerned	HERMOSA
04/07/23 10:12:16	CFS2303251		AMB	AMB : Ambulance Calls	HERMOSA
04/07/23 21:59:29	CFS2303267		EXT	EXT : Extra Patrol	HERMOSA
04/08/23 11:51:02	CFS2303279		911M	911M : 911 Misdial	HERMOSA
04/08/23 19:10:12	CFS2303295		PAPSERV	PAPSERV : Paper Service	HERMOSA
04/08/23 21:54:36	CFS2303300		EXT	EXT : Extra Patrol	HERMOSA
04/08/23 22:36:21	CFS2303302		AOA	AOA : Assist Other	HERMOSA
04/09/23 06:01:43	CFS2303307		EXT	EXT : Extra Patrol	HERMOSA
04/09/23 22:33:08	CFS2303321		EXT	EXT : Extra Patrol	HERMOSA
04/10/23 15:03:35	CFS2303336		ALRF	ALRF : Fire Alarm	HERMOSA
04/11/23 07:10:44	CFS2303355		AMB	AMB : Ambulance Calls	HERMOSA

CFS Date/Time	CFS #	Case Number	Code	Code : Description	Zone
04/11/23 10:31:41	CFS2303360		VEHABND	VEHABND : Abandoned	HERMOSA
04/11/23 13:57:13	CFS2303365		EXT	EXT : Extra Patrol	HERMOSA
04/12/23 00:07:39	CFS2303374		EXT	EXT : Extra Patrol	HERMOSA
04/12/23 07:36:51	CFS2303377		SPATROL	SPATROL : School Patrol	HERMOSA
04/12/23 13:27:03	CFS2303390		EXT	EXT : Extra Patrol	HERMOSA
04/13/23 06:09:03	CFS2303407		EXT	EXT : Extra Patrol	HERMOSA
04/13/23 07:39:31	CFS2303410		SPATROL	SPATROL : School Patrol	HERMOSA
04/13/23 16:06:22	CFS2303428	2023-00163	DISCOND	DISCOND : Disorderly	HERMOSA
04/13/23 23:27:46	CFS2303431		EXT	EXT : Extra Patrol	HERMOSA
04/14/23 08:27:01	CFS2303432		EXT	EXT : Extra Patrol	HERMOSA
04/14/23 22:10:38	CFS2303455		EXT	EXT : Extra Patrol	HERMOSA
04/16/23 00:58:17	CFS2303493		TRANSFER	TRANSFER : Transfer	HERMOSA
04/16/23 05:59:28	CFS2303497		EXT	EXT : Extra Patrol	HERMOSA
04/16/23 20:22:46	CFS2303515		EXT	EXT : Extra Patrol	HERMOSA
04/17/23 05:47:20	CFS2303521	2023-00174	VANDAL	VANDAL : Vandalism	HERMOSA
04/17/23 06:53:20	CFS2303524		SPATROL	SPATROL : School Patrol	HERMOSA
04/17/23 07:37:32	CFS2303525		SPATROL	SPATROL : School Patrol	HERMOSA
04/17/23 18:42:45	CFS2303539		EXT	EXT : Extra Patrol	HERMOSA

CFS Date/Time	CFS #	Case Number	Code	Code : Description	Zone
04/17/23 22:33:54	CFS2303543		EXT	EXT : Extra Patrol	HERMOSA
04/17/23 23:20:30	CFS2303544		THEFTMV	THEFTMV : Theft - Motor	HERMOSA
04/18/23 02:07:47	CFS2303548		EXT	EXT : Extra Patrol	HERMOSA
04/18/23 07:34:09	CFS2303552		SPATROL	SPATROL : School Patrol	HERMOSA
04/18/23 15:48:39	CFS2303563	2023-00176	ATT/BREAK	ATT/BREAK :	HERMOSA
04/18/23 21:26:24	CFS2303570		EXT	EXT : Extra Patrol	HERMOSA
04/19/23 00:10:44	CFS2303577		EXT	EXT : Extra Patrol	HERMOSA
04/20/23 00:51:48	CFS2303611		EXT	EXT : Extra Patrol	HERMOSA
04/20/23 14:08:35	CFS2303628		911A	911A : 911 Abandoned	HERMOSA
04/20/23 16:43:23	CFS2303632		EXT	EXT : Extra Patrol	HERMOSA
04/20/23 22:03:02	CFS2303644		EXT	EXT : Extra Patrol	HERMOSA
04/20/23 22:58:54	CFS2303648		DISCOND	DISCOND : Disorderly	HERMOSA
04/21/23 21:00:42	CFS2303673		ODOR	ODOR : Odor	HERMOSA
04/22/23 11:22:52	CFS2303683		CONT	CONT : Continuation Of	HERMOSA
04/23/23 06:32:21	CFS2303715		EXT	EXT : Extra Patrol	HERMOSA
04/23/23 22:27:08	CFS2303733		EXT	EXT : Extra Patrol	HERMOSA
04/24/23 19:27:10	CFS2303761		ANI	ANI : Animal Complaints	HERMOSA
04/25/23 02:03:02	CFS2303771		EXT	EXT : Extra Patrol	HERMOSA

CFS Date/Time	CFS #	Case Number	Code	Code : Description	Zone
04/25/23 07:40:02	CFS2303773		SPATROL	SPATROL : School Patrol	HERMOSA
04/25/23 14:54:25	CFS2303791		ANL	ANL : Animal Lost	HERMOSA
04/25/23 16:26:55	CFS2303795		PAPSERV	PAPSERV : Paper Service	HERMOSA
04/25/23 23:19:13	CFS2303808		EXT	EXT : Extra Patrol	HERMOSA
04/25/23 23:20:01	CFS2303809		MOTASST	MOTASST : Motorist	HERMOSA
04/26/23 04:03:35	CFS2303810		AMB	AMB : Ambulance Calls	HERMOSA
04/26/23 10:52:43	CFS2303821		PAPSERV	PAPSERV : Paper Service	HERMOSA
04/26/23 12:15:14	CFS2303823		EXT	EXT : Extra Patrol	HERMOSA
04/26/23 15:09:55	CFS2303834		SPATROL	SPATROL : School Patrol	HERMOSA
04/27/23 06:48:38	CFS2303850	2023-00194	DEATH	DEATH : Death / Coroner	HERMOSA
04/27/23 22:17:39	CFS2303868		EXT	EXT : Extra Patrol	HERMOSA
04/28/23 23:29:19	CFS2303893		EXT	EXT : Extra Patrol	HERMOSA
04/29/23 06:00:38	CFS2303898		EXT	EXT : Extra Patrol	HERMOSA
04/30/23 06:11:26	CFS2303931		EXT	EXT : Extra Patrol	HERMOSA
04/30/23 19:21:20	CFS2303949		CIVIL	CIVIL : Civil Matter	HERMOSA
04/30/23 22:29:48	CFS2303954		EXT	EXT : Extra Patrol	HERMOSA

Total Records: 84

97.

From: lberg@proacesinc.com
Sent: Wednesday, February 8, 2023 10:48 AM
To: Monika Serviss; 'Dan H.'; 'Linda Kramer'
Cc: 'Daniel Finch'
Subject: Hermosa Booster Pump Upgrades

Dan and Town of Hermosa,

We have gone over the current conditions of the existing 2" booster pump and vault with Dakota Pump. We reached out to Dakota Pump since they supplied the original system as it was designed. I have attached the existing layout for reference.

Based on the fire flow requirement of 250 gpm and the head conditions with 6" piping, the existing vault and components are all undersized for that type of an upgrade or improvement.

This simply means that the existing booster pump and vault will be removed and a larger vault and pumping system installed.

The new booster pump system with vault and installation should have a budget cost of \$200,000.

This will need to be designed, plans and specifications produced and submitted to the State and the project will need to be publicly bid. Beyond that construction administration through the construction process. The surveying and engineering should be at a budget of \$50,000.

Moving forward for planning the project cost budget should be \$250,000.

I believe this was the information needed for the Town to make decisions moving forward.

Thank you,
Leah M. Berg, P.E.
Civil Engineer / President



Affordably Creative Engineering Services, Inc
324 St. Joseph St, Suite 200
Rapid City, SD 57701
Fax 605-716-1144
Phone 605-716-4646
Cell 605-545-1120
L.Berg@proacesinc.com

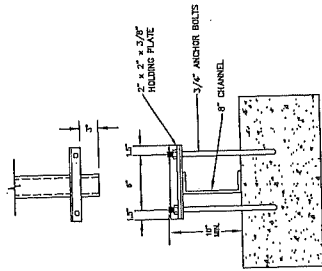

ANCHOR DETAIL
NTS

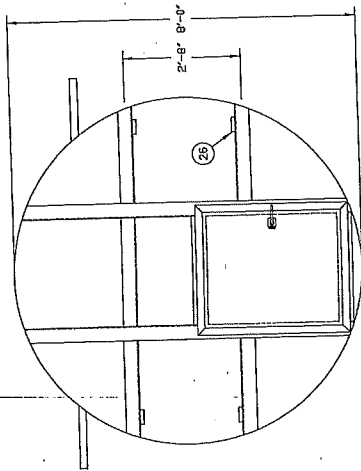

TOP-DETAIL

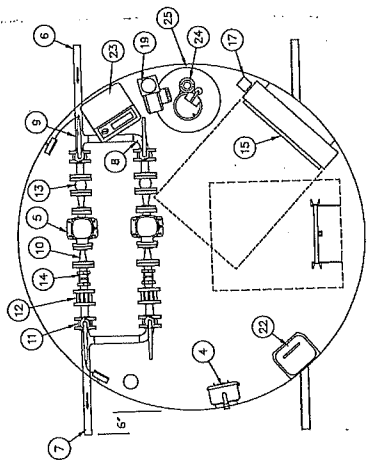

PLAN VIEW

ITEM QUANTITY	DESCRIPTION
28	STATION INSULATION - URETHANE FOAM SPRAYED TO AN INSULATING VALUE OF R-19
28	FLOOR MATING - PLACED IN ALL NORMAL WALKWAYS AND WORK AREAS
27	MAINTENANCE LIFTING HOOKS
26	STATION LIFTING HOOKS - PLACED FOR BALANCED FIELD SETTING
25	1 SUMP PIT - 18" DIA. X 8" DEEP
24	1 SUMP PUMP - ZOLLER S3 W/STEEL DISCHARGE AND REQUIRED FITTINGS
23	1 DEHUMIDIFIER - 25 P7/DAY W/DRAIN TO SUMP
22	1 HEATER - 1500 WATT
21	1 STATION LIGHTING - FLUORESCENT VAPOR TIGHT
20	1 4" DIA. STEEL INTAKE/EXHAUST VENTS W/180° BENDS AND SCREENS
19	1 VENTILATION BLOWER - DAYTON 4C447
18	CONDUITS - SEE BILL OF MATERIALS FOR A COMPLETE LISTING
17	3 PRESSURE SWITCHES
16	2 PRESSURE GAUGES - WALL MOUNTED
15	1 POWER & CONTROL PANEL
14	2 2" DRESSER 65 COUPLINGS
13	2 2" METRAFLEX METRASHIPPERS
12	2 2" METRAFLEX 700 SILENT CHECK VALVES
11	4 2" WATTS BF-04 BUTTERFLY VALVES W/LEVER OPERATORS
10	4 2"x1.25" STEEL WELD ECCENTRIC REDUCER
9	2 2"x2"x2" STEEL WELD TEES
8	2 2" STEEL WELD ELBOWS
7	1 2" DIA. SCH. 40 STEEL DISCHARGE LINE W/PLAIN END CONNECTION TO THE STATION
6	1 2" DIA. SCH. 40 STEEL SUCTION LINE W/PLAIN END CONNECTION TO THE STATION
5	2 PUMPS & MOTORS - GRUNDFOS CR 5-3, 1 H.P., 3500 R.P.M., 230V/FRN/60HZ
4	CONDITIONS: 20 C.P.M. at 75 T.O.H.
3	1 CATHODIC PROTECTION - FOUR (4) 178 ANODES W/TEST PANEL
2	1 ENTRANCE LADDER - ALUMINUM W/BUILD LU-1 LADDER-UP ASSIST
1	1 ENTRANCE HATCH - BILDO S-50
1	1 EQUIPMENT CHAMBER - 3/8" PLATE TOP & BOTTOM, 1/4" SIDES, 4"x4"x1/4" ANGLE TOP REINF., 8" CHANNEL SIDES W/8" CHANNEL CROSSMEMBERS

PROJECT: HERMOSA, SD
Water Booster Station

DAKOTA PUMP INC.
Riverside Road, Interstate 1-80
Mitchell, S.D. 57301
Phone: (605) 866-6888
Fax: (605) 866-6087

DATE: 9-29-05 REV. 1-17-C
DRAWN-BY: CS
PROP: # 05-99-03 EQUIP
SCALE: 1/2"=1'-0"

THIS DRAWING IS NOT FOR CONSTRUCTION PURPOSES
UNLESS SPECIFICALLY NOTED OTHERWISE.
LATEST REVISIONS WILL BE FURNISHED UPON REQUEST.

Design and Fabrication of
Pumps and Motors
Handling Equipment

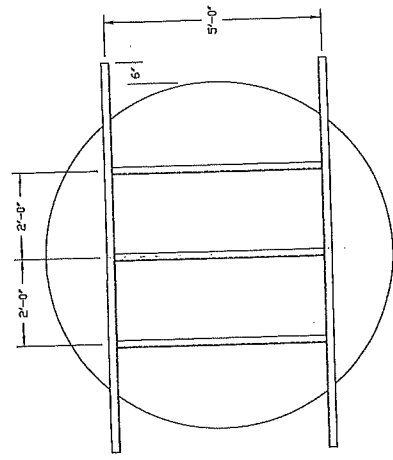

BOTTOM DETAIL

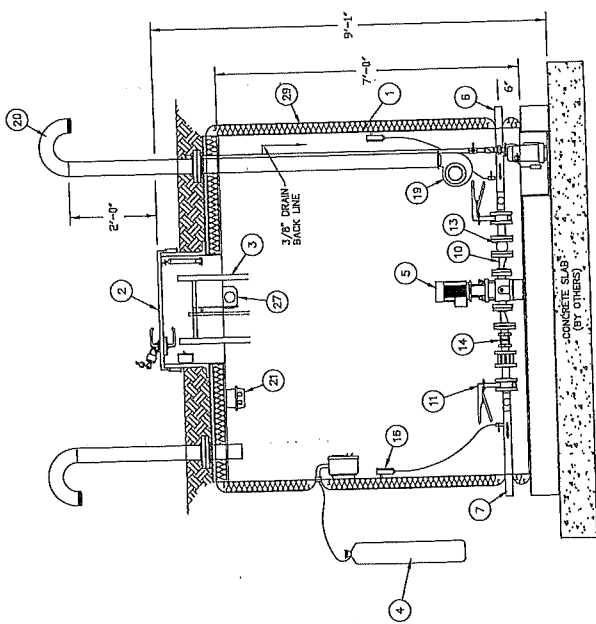

PROFILE VIEW

**HERMOSA PLANNING & ZONING BOARD
REGULAR MEETING
May 9, 2023 @ 6:00pm**



10 A.

ROLL CALL: Harris called the meeting to order at 6:00pm with the following members present; Harris, Waltman, Irvine, Westergard and Klaski, Liaison Henrichsen. Pledge of Allegiance led by Harris.

CALL FOR CHANGES: Motion made; seconded to amend the agenda and add 6d) - Fences. Vote; all aye; motion carried.

CONSENT CALENDAR: Motion made; seconded to approve the April 25, 2023, meeting minutes. Vote; all aye; motion carried.

CONFLICT OF INTEREST DECLARATION: None

OLD BUSINESS:

Permit 2022-18 – Custer County Concession Stand – Pending
Permit 2022-25 – Parcels 009318 & 009319 – Design for Sewer System - Pending

NEW BUSINESS:

Permit 2023-15 – Informational Permit – 27 N. 4th St. – Replace back deck with 10x16 concrete deck. Motion made, seconded to approve. Vote; all aye; motion carried.
Permit 2023-16 – Informational Permit – 160 N. 3rd St. – Citizen seeking direction on using north side of residential property as a business for trailer storage. North 3rd street ends at citizens driveway. The road would need to be improved to the north to accommodate additional traffic. The town has no plans in the works to complete the road to north at this time. The property for the proposed storage area is in the floodplain and would need a staff report from a Floodplain Engineer. Conversation included the lot would need to be replated and the venture is a business and lot rezoned from Residential to Commercial.
Request from Hermosa Connects, Inc. to waive \$25.00 vendor fees for June 24, 2023, Vendor Fair & Farmers Market – Board verified it would not make each individual vendor pay the application fee and waive the fee for the Hermosa Community Center. Discussion regarding Food Vendor’s are still required to complete the Town’s Transient Vendor & Peddlers Application. Application states “All food vendors must be registered with the County and/or State Board of Health and present proof of that registration with their submission; and all current governmental registrations and licenses must be displayed at the sale.” Motion made and seconded to waive all vendor fees for event to include Hermosa Community Center but require all Food Vendors/Trucks to complete application and pay \$25.00 fee. Vote; all aye; motion carried.
Fences – Harris requested the citizens that put a fence around parcel 009190 complete an Informational Permit for the fence installation.

REVIEW BOT MINUTES: May 2, 2023

ORDINANCE REVIEW & WORK ITEMS:

Contractors Licensing Ordinance – Chapter 112 - 112.03 – Board agreed to read through the examples attached in the packet and present their ideas and comments at the next P&Z meeting, from there it will go to a work session.
Solar (Panels) Ordinance – Pending
Review of 2018 Comprehensive Plan – Pending

COMPLETED WORK ITEMS SENT TO BOT:

TRUSTEE INPUT:

CITIZEN INPUT:

ADJOURN: Motion made, seconded to adjourn the meeting at 6:37 pm; Vote; all aye; motion carried.

Joan Harris, Planning & Zoning Board President

Jill Dybvig, Administrative Assistant

There may be a quorum of Board of Trustees present at Planning & Zoning Meetings

Town of Hermosa

10 D.

PO Box 298 • 230 Main Street • Hermosa, SD 57744
Phone (605) 255-4291 • Fax (605) 255-4094
Email: town@hermosasd.com

DATE 8/1/23

PERMIT # 2023-15

Informational Permit No Fee

Is Property in the Flood Plain? Yes No Zoning District R-2

***IF YES - YOU NEED A FLOOD PLAIN DEVELOPMENT PERMIT**

Property Owner Name(s): John & Crystal Wiles

Mailing Address: PO Box 241
Hermosa SD 57740

Email: johnwiles.realtor@gmail.com

Address of Project: 27 N. 4th St

Legal Description: Lot R White Oak Estates SW4SW4SEC29T2R8
Subdivision _____ Block _____ Lot(s) Lot Size .858 acres

Description of Work: Remove back deck & replace with concrete

i.e. Fence below 4' (front yard), 6' (side/rear yard), Accessory Building/Deck less than 160 sq.ft.; Sidewalk; Driveway; Concrete; Renovation / Remodel / Repairs / Maintenance not requiring Building Permit (i.e. shingle replacement)

Total Cost Estimate of Project \$3400 Total Square Footage of Project 160 (10x16)

~~Building Area (Sq. Ft.)~~ _____ Height: _____

Accessory Bldg. Setbacks From Lot Lines: Front: _____ Ft. (20' Town Minimum)

(See Ord.155) Rear: _____ Ft. (5' Town Minimum)

Side: _____ Ft. (8' Town Minimum)

Side: _____ Ft. (8' Town Minimum)

Licensed Contractor / Person doing work Homeowner

Address of Contractor / Person _____

Contact Phone Number of Contractor / Person 605-431-9332

Parcel # 013915
OFFICE USE

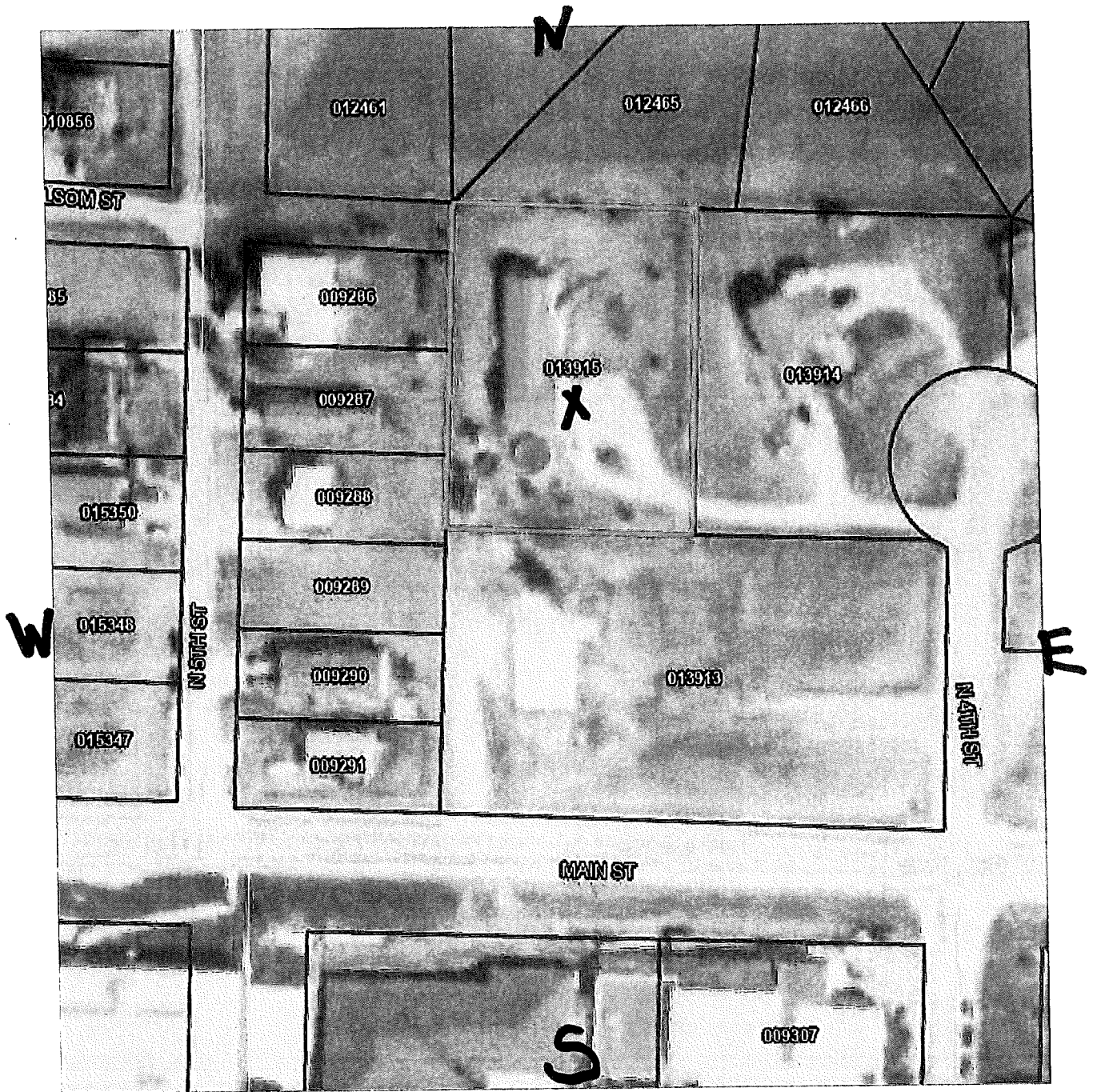

Alternate IDn/a
 Class Residential
 Acreage 0.858

Owner Address WILES JOHN S & CRYSTAL G JT WROS
 PO BOX 341
 HERMOSA, SD 57744-0341

16.1-7-0-0-2
 WHITERAIL ESTATES SUB - LOT R (FORM LOTS 1-10 OF TR B OF WARREN TR) IN SW4SW4 SEC 29 T2 R8 .858 AC
 7440005100001402

013915

Town of Hermosa

10 E.

PO Box 298 • 230 Main Street • Hermosa, SD 57744
Phone (605) 255-4291 • Fax (605) 255-4094
Email: town@hermosasd.com

Vendors
Fair +
Farmers
Market

TRANSIENT VENDOR & PEDDLERS APPLICATION

DATE _____

Receipt # _____ Cash _____ Check # _____ Amount _____

Transient Vendor & Peddler Information _____
Company Name _____
Owner/President _____
Mailing Address _____
Email _____
Phone _____ Cell _____
Description of Items to Be Sold _____
Location of Temporary Business _____
Times When the Sales Will Be Conducted _____
South Dakota Vendor License _____
South Dakota Sales Tax License # _____



Fees: 1 day - \$25.00 7 days - \$100.00 Monthly - \$300.00 + 5%

The Above Information Is True and Correct

Vendor Signature _____

Date _____

Applicants applying for a special event vendor license shall present to any entity sponsoring the event the following:

- * Name, address and phone number of the person, partnership, partner, corporation, or similar business entity;
- * A description of the nature of the sales to be conducted and type of business that will conduct sales;
- * Description of the location where the sales will be conducted within the town;
- * The times when the sales will be conducted within the town;
- * License or permits with the county and/or the state;
- * If electrical access, open fires, or use of propane: certificate from Fire Marshal's office showing that all codes are met;
- * All food vendors must be registered with the County and/or State Board of Health and present proof of that registration with their submission; and
- * All current governmental registrations and licenses must be displayed at the sale.

License #

Office Use Only

CHAPTER 113: PEDDLERS, SOLICITORS AND VENDORS

Section

- 113.01 Purpose
- 113.02 Definitions
- 113.03 License
- 113.04 Fees
- 113.05 Duration
- 113.06 Exemptions
- 113.07 Hours
- 113.08 Special provisions
- 113.09 Zoning and other regulations
- 113.10 Enforcement

- 113.99 Penalty

§ 113.01 PURPOSE.

(A) For the protection of the citizens of the town, and to prevent undesired, unhealthful and/or criminal activity.

(B) The town shall require all transient vendors and peddlers to register with, and obtain a vendor's permit from the town office prior to commencing business within the jurisdictional boundaries of the town.

(Ord. 1.004R, passed 9-6-2011)

§ 113.02 DEFINITIONS.

For the purpose of this chapter, the following definitions shall apply unless the context clearly indicates or requires a different meaning.

EMERGENCY SITUATION. An unforeseen occurrence that requires immediate attention, the absence of which would endanger the health or safety of others, cause the loss of perishable goods, or create an economic hardship due to the unavoidable imminent nature of the circumstance.

From: Hermosa Connects Inc
Sent: Monday, April 24, 2023 3:14 PM
To: Monika Serviss
Subject: Re: Vendor registration with the Town

Monika,

I have a question that I would like to see the to the board.
Could we waive these fees this year as it is the first for this organization?
We are communicating with these vendors and putting in some thoughtful work into this community event and its organization.
Thank you!
Valena

On Apr 24, 2023, at 10:11 AM, Monika Serviss <monika@hermosasd.com> wrote:

Hi Valena,
Please see attached Town ordinance for the vendors and the application form. Please let me know if you have any questions and I will address it to the board.

Thank you,

Monika Serviss

Finance Officer
Town of Hermosa
605-255-4291
<83C2DA1650414D32916BC10D724AE595[4996672].png>
230 Main St., PO Box 298
Hermosa, SD 57744

From: scancopier@gmail.com
Sent: Monday, April 24, 2023 10:06 AM
To: Monika Serviss
Subject: Message from "RNP58387933868C"

This E-mail was sent from "RNP58387933868C" (IM C4500).

Scan Date: 04.24.2023 10:25:34 (-0400)
Queries to: scancopier@gmail.com

<20230424102534869.pdf>

Vendor Fair

— AND —

FARMERS

MARKET

SAT. JUNE 24, 2023

8 A.M. - 3 P.M.

**AT THE HERMOSA
COMMUNITY CENTER**

122 Vilas St, Hermosa, SD

**VENDORS / FRESH GARDEN
PRODUCE / CHICKEN
RACES / CHICKEN POOP
BINGO / FOOD & MORE!**

Vendor registration at:

WWW.HERMOSACONNECTS.COM

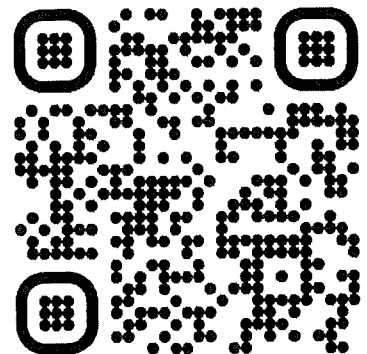
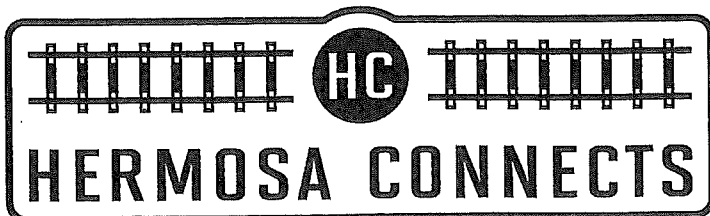

12 A.

Transaction No	Date	Mod	Emp1/Vend	Vendor/Employee Name	Other No	Checks	Deposits
1						Beginning Statement Balance	812,750.73
285	3/21/2023	RM					363.80
286	3/22/2023	RM					199.60
287	3/23/2023	RM					1,231.30
288	3/24/2023	RM					283.52
290	3/26/2023	RM					1,128.68
300	3/27/2023	RM					170.00
301	3/28/2023	RM					1,192.15
302	3/29/2023	RM					199.60
304	3/30/2023	RM					100.00
305	4/02/2023	RM					1,905.34
306	3/20/2023	BK		Kelly Colleen			82.00
312	4/01/2023	BK					209.32
313	4/02/2023	BK					144.55
314	4/03/2023	RM					1,337.55
315	4/05/2023	RM					659.36
316	4/07/2023	RM					198.00
317	4/09/2023	RM					604.20
318	4/06/2023	RM					100.00
319	4/10/2023	RM					888.81
320	4/11/2023	RM					1,258.50
321	4/07/2023	BK					123.01
322	4/08/2023	BK					111.70
323	4/09/2023	BK					249.40
324	4/13/2023	RM					3,323.12
325	4/12/2023	RM					454.60
326	4/13/2023	RM					1,279.70
327	4/14/2023	RM					807.60
328	4/16/2023	RM					1,240.50
329	4/12/2023	BK					1,904.68
330	4/14/2023	BK					199.60
331	4/18/2023	RM					426.78
332	4/17/2023	RM					419.44
333	4/19/2023	RM					499.40
334	4/20/2023	BK					99.80
335	4/19/2023	BK					869.62
336	4/18/2023	BK					93.77
337	4/15/2023	BK					7,074.42
338	4/16/2023	BK					546.10
339	4/21/2023	BK					470.71
340	4/23/2023	BK					105.20
341	4/13/2023	BK					398.38
342	4/25/2023	RM					1,800.10
343	4/20/2023	RM					100.00
344	4/21/2023	RM					259.60
345	4/24/2023	RM					280.00
346	4/25/2023	RM					711.30
347	4/27/2023	GL					23,773.50
348	4/27/2023	GL					937.24
349	4/27/2023	GL					614.68
350	4/27/2023	GL					14,766.53
352	4/22/2023	BK					129.80
354	4/28/2023	BK					623.24

Transaction No	Date	Mod	Emp1/Vend	Vendor/Employee Name	Other No	Checks	Deposits
1 PIONEER BANK & TRUST CHECKING					- continued -		
361	4/26/2023	BK					302.18
362	4/27/2023	BK					279.16
364	4/30/2023	GL					97.71
16956	12/06/2022	AP	46	BRIDGET SHORB		59.15	
17088*	3/21/2023	AP	18	ACES Engineering INC	16,585.00		
17089	3/21/2023	AP	20	DSG-DAKOTA SUPPLY GROUP		344.45	
17093*	3/21/2023	AP	4	ODP BUSINESS SOLUTIONS LLC		187.85	
17096*	3/30/2023	PR	1	VONDA BELT		135.06	
17097	3/30/2023	PR	3	JOAN E HARRIS		221.64	
17098	3/30/2023	PR	9	VICKI L HENRICHSEN		161.61	
17099	3/30/2023	PR	10	DANNY J HOLSWORTH		410.96	
17100	3/30/2023	PR	15	CHARLES IRVINE		138.52	
17101	3/30/2023	PR	16	BOBBIE KLASKI		110.82	
17102	3/30/2023	PR	4	LINDA M KRAMER		377.35	
17103	3/30/2023	PR	12	TERRI V SCHUMACK		230.87	
17104	3/30/2023	PR	5	MONIKA SERVISS	1,468.34		
17105	3/30/2023	PR	17	TANYA L STOCKHAM		55.41	
17106	3/30/2023	PR	6	JILL R SWIER-DYBVG	1,102.94		
17107	3/30/2023	PR	7	LON WALTMAN		166.23	
17108	3/30/2023	PR	18	Bradley L Westergard		55.41	
17109	3/30/2023	AP	3	SOUTH DAKOTA RETIREMENT SYSTEM		922.20	
17110	3/30/2023	AP	23	CHUCK FERGUSON	2,600.00		
17111	4/04/2023	AP	32	CLAYCOMB ENGINEERING		712.00	
17113*	4/04/2023	AP	26	HEALTH POOL OF SOUTH DAKOTA		1,835.74	
17114	4/04/2023	AP	41	JOHNSON LAW OFFICE		1,513.00	
17115	4/04/2023	AP	43	Southern Hills Publishing		299.27	
17116	4/04/2023	AP	80	Summit Signs and Supply Inc.		950.00	
17117	4/04/2023	AP	64	Temperature technology Inc.		319.39	
17118	4/04/2023	AP	18	ACES Engineering INC		1,850.00	
17119	4/04/2023	AP	82	Independent audit services		3,750.00	
17120	4/14/2023	PR	5	MONIKA SERVISS		1,341.37	
17121	4/14/2023	PR	6	JILL R SWIER-DYBVG		1,102.94	
17122	4/18/2023	AP	83	Bradley Westerguard		402.78	
17123	4/18/2023	AP	23	CHUCK FERGUSON		3,293.00	
17124	4/18/2023	AP	33	GOLDEN WEST TECHNOLOGIES		563.50	
17125	4/18/2023	AP	66	Midcontinent testing lab. Inc		1,284.25	
17126	4/18/2023	AP	71	Nelson's Oil & Gas Inc.		36.00	
17127	4/18/2023	AP	65	SOUTH DAKOTA 811		16.80	
93*	4/04/2023	AP	14	US BANK		3,820.54	
94	4/04/2023	AP	12	RURAL DEVELOPMENT		1,278.00	
95	4/04/2023	AP	12	RURAL DEVELOPMENT		417.00	
96	4/04/2023	AP	12	RURAL DEVELOPMENT		222.00	
97	4/04/2023	AP	8	MT RUSHMORE TELEPHONE		257.24	
98	4/04/2023	AP	11	PIONEER BANK & TRUST		212.89	
99	4/04/2023	AP	6	A & B BUSINESS EQUIPMENT INC		557.91	
100	4/14/2023	AP	1	EFTPS-Electronic Federal Tax		554.03	
101	4/18/2023	AP	13	SANDERS SANITATION		4,470.84	
102	4/18/2023	AP	40	BLACK HILLS ELECTRIC COOP.,Inc		3,388.59	
103	4/28/2023	AP	1	EFTPS-Electronic Federal Tax		850.41	
104	4/28/2023	AP	14	US BANK		68,981.35	
108	4/28/2023	AP	11	PIONEER BANK & TRUST		25.00	

Transaction No	Date	Mod	Empl/Vend	Vendor/Employee Name	Other No	Checks	Deposits
1				WEER BANK & TRUST CHECKING			

- continued -

Fund Description

101	GENERAL					31,008.84	41,619.41
211	BBB GROSS RECEIPTS TAX					363.28	1,784.88
301	DEBT SERVICE					72,801.89	7,949.91
602	WATER					19,814.09	17,370.89
604	SEWER					5,651.55	8,674.29
	Fund Grand Total					129,639.65	77,399.38

Ending Statement Balance 760,739.93

Transaction No	Date	Mod	Empl/Vend	Vendor/Employee Name	Other No	Checks	Deposits
1				DEER BANK & TRUST CHECKING			
						Beginning Statement Balance	812,750.73
				48 Credit Transactions		129,639.65	
				55 Debit Transactions			77,628.85
						Ending Statement Balance	760,739.93

OUTSTANDING TRANSACTION REGISTER

OPEN

MOD CODE	BANK NO	NAME	NUMBER	DATE	PERIOD	VEND/EMPL	OTHER NUMB	DEPOSITS	CHECKS AND WITHDRAWALS	RECONCILING	VOIDED	MANUAL
1 PIONEER BANK & TRUST CHECKING STATEMENT DATE: 4/30/2023												
RM DEP	351	4/26/23	04/23	DEPOSIT				819.80				
RM DEP	353	4/27/23	04/23	DEPOSIT				1,845.60				
RM DEP	355	4/30/23	04/23	DEPOSIT				2,426.14				
BK DEP	363	4/29/23	04/23	CR Card Deposit				428.65				
BK CHK	16695	5/04/22	06/22	SOUTH DAKOTA MUNICIPAL LE					156.00			
BK CHK	16726	6/08/22	06/22	CHUCK IRVINE					10.00			
BK CHK	16875	10/08/22	10/22	DAVID ARLEDGE					125.00			
UB CHK	17064	2/21/23	02/23	PREBLE MARK & DAWN					25.20			
AP CHK	17112	4/04/23	04/23	DOOR SECURITY PROD					927.55			
PR CHK	17128	4/28/23	04/23	BELT, VONDA					96.97			
PR CHK	17129	4/28/23	04/23	HENRICHSSEN, VIC					184.70			
PR CHK	17130	4/28/23	04/23	HOLSWORTH, DANN					184.70			
PR CHK	17131	4/28/23	04/23	KRAMER, LINDA M					252.22			
PR CHK	17132	4/28/23	04/23	SCHUMACK, TERRI					138.52			
PR CHK	17133	4/28/23	04/23	SERVISS, MONIKA					1,433.71			
PR CHK	17134	4/28/23	04/23	SWIER-DYBVIIG, J					1,049.66			
AP CHK	17135	4/28/23	04/23	SOUTH DAKOTA RETIREMENT					724.30			
AP CHK	17141	4/28/23	04/23	FERGUSON CHUCK					2,600.00			
BANK TOTAL								5,520.19	7,908.53	.00		
DEPOSITS-CHECKS								2,388.34-				

BANK NO	DATE	JOURNAL	PENDING DEPOSITS	ADJUSTMENTS*
1	1/06/2023	RM 0052	816.40	.00
1	1/06/2023	RM 0054	816.40-	.00
1	3/17/2023	RM 0383	99.80	.00
1	3/17/2023	RM 0416	99.80-	.00
1	4/26/2023	RM 0535	73.50	5.00
1	4/28/2023	RM 0545	490.09	.00
1	4/30/2023	RM 0547	98.90	.90
BANK TOTAL			662.49	5.90
REPORT TOTAL			662.49	

*Adjustments include fees and returns that reduce GWorks Payments Deposits.

BALANCE SHEET
CALENDAR 5/2023, FISCAL 5/2023

ACCOUNT NUMBER	ACCOUNT TITLE	PTD BALANCE	YTD BALANCE
101-00000-10100	CASH	13,664.32-	292,260.42
211-00000-10100	CASH	304.83-	65,824.03
301-00000-10100	CASH		54,225.97
602-00000-10100	CASH	4,775.66-	151,707.42
602-00000-10700	CASH - RESERVE		11,218.84
602-00000-10800	CASH - CUSTOMER DEP RSRV	219.91-	9,195.70
602-00000-11500	UNDIST RCPTS UTILITY AR		5,407.42-
604-00000-10100	CASH	3,602.80	158,911.85
604-00000-10700	CASH - RESERVE		313.83
	CASH TOTAL	----- 15,361.92-	----- 738,250.64
272-00000-10150	CASH - CONSTRUCTION		1,500.00
	CASH - CONSTRUCTION TOTAL	----- .00	----- 1,500.00
101-00000-10300	PETTY CASH		232.98
	PETTY CASH TOTAL	----- .00	----- 232.98
101-00000-10400	CASH INVESTED - SDFIT		43,317.06
602-00000-10400	CASH INVESTED - SDFIT		30,876.67
604-00000-10400	CASH INVESTED - SDFIT		67,119.04
	CASH INVESTED - SDFIT TOTAL	----- .00	----- 141,312.77
	TOTAL CASH	=====	=====
		15,361.92-	881,296.39
		=====	=====

TREASURER'S REPORT
CALENDAR 5/2023, FISCAL 5/2023

FUND#	TITLE	LAST MONTH CASH BALANCE	REVENUES	EXPENSES	LIABILITY BALANCE	THIS MONTH CASH BALANCE
101	GENERAL	349,474.78	10,333.71	23,922.25	336,988.71	335,810.46
211	BBB GROSS RECEIPTS TAX	66,128.86		304.83	61,903.70	65,824.03
272	FEMA/CONSTRUCTION	1,500.00			1,500.00	1,500.00
301	DEBT SERVICE	54,225.97			105,121.38	54,225.97
602	WATER	202,586.78	7,853.26	12,630.23	187,303.70	197,591.21
604	SEWER	222,741.92	4,840.81	1,238.80	199,103.19	226,344.72
<hr/>						
	Report Total	896,658.31	23,027.78	38,096.11	891,920.68	881,296.39

REVENUE REPORT
CALENDAR 5/2023, FISCAL 5/2023

PCT OF FISCAL YTD 41.6%

ACCOUNT NUMBER	ACCOUNT TITLE	FISCAL ESTIMATE	PTD BALANCE	YTD BALANCE	PERCENT RECVD	UNCOLLECTED
	GENERAL TOTAL	466,735.00	10,333.71	172,375.26	36.93	294,359.74
	BBB GROSS RECEIPTS TAX TOTAL	8,307.00	.00	5,223.48	62.88	3,083.52
	FEMA/CONSTRUCTION TOTAL	1,500.00	.00	.00	.00	1,500.00
	DEBT SERVICE TOTAL	16,810.00	.00	25,727.02	153.05	8,917.02-
	WATER TOTAL	659,750.00	7,853.26	72,269.57	10.95	587,480.43
	SEWER TOTAL	128,220.00	4,840.81	44,931.27	35.04	83,288.73
	TOTAL REVENUE BY FUND	=====	=====	=====	=====	=====
		1,281,322.00	23,027.78	320,526.60	25.02	960,795.40
		=====	=====	=====	=====	=====

Expendence

101 General Fund

ACCOUNT NUMBER	ACCOUNT TITLE	TOTAL BUDGET	PTD BALANCE	YTD BALANCE	PERCENT EXPENDED	UNEXPENDED
	LEGISLATIVE TOTAL	32,220.38	230.71	6,397.21	19.85	25,823.17
	ELECTIONS TOTAL	1,215.00	.00	.00	.00	1,215.00
	FINANCIAL ADMINISTRATION TOTA	131,465.00	6,751.75	52,332.72	39.81	79,132.28
	LEGAL TOTAL	25,000.00	799.00	7,402.50	29.61	17,597.50
	GENERAL GOV'T BUILDINGS TOTAL	1,936.00	.00	536.91	27.73	1,399.09
	ENGINEER TOTAL	50,000.00	.00	26,927.90	53.86	23,072.10
	POLICE TOTAL	88,000.00	8,666.67	37,333.35	42.42	50,666.65
	PROTECTIVE INSPECTION TOTAL	3,000.00	.00	245.00	8.17	2,755.00
	PUBLIC WORKS TOTAL	77,213.62	3,098.10	19,622.09	25.41	57,591.53
	SOLID WASTE COLLECTION TOTAL	51,990.00	4,376.02	21,767.32	41.87	30,222.68
	PLANNING/ZONNING TOTAL	4,695.00	.00	1,021.15	21.75	3,673.85
	GENERAL TOTAL	466,735.00	23,922.25	173,586.15	37.19	293,148.85
	URBAN REDEVELOP/HOUSING TOTAL	4,500.00	.00	.00	.00	4,500.00

TOWN OF HERMOSA
BUDGET REPORT
CALENDAR 5/2023, FISCAL 5/2023

ACCOUNT NUMBER	ACCOUNT TITLE	TOTAL BUDGET	PTD BALANCE	YTD BALANCE	PERCENT EXPENDED	UNEXPENDED
211 BBB	PROMOTING THE CITY TOTAL	.00	304.83	1,303.15	.00	1,303.15-
	TRANSFERS OUT TOTAL	3,807.00	.00	.00	.00	3,807.00
	BBB GROSS RECEIPTS TAX TOTAL	8,307.00	304.83	1,303.15	15.69	7,003.85
272 FEMA	URBAN REDEVELOP/HOUSING TOTAL	1,500.00	.00	.00	.00	1,500.00
	FEMA/CONSTRUCTION TOTAL	1,500.00	.00	.00	.00	1,500.00
301 Debts.	DEBT SERVICE TOTAL	16,810.00	.00	76,622.43	455.81	59,812.43-
	DEBT SERVICE TOTAL	16,810.00	.00	76,622.43	455.81	59,812.43-
602 WATER	WATER TOTAL	598,263.00	9,539.50	50,987.71	8.52	547,275.29
	DEBT SERVICE TOTAL	27,661.00	3,090.73	10,973.95	39.67	16,687.05
	TRANSFERS OUT TOTAL	33,826.00	.00	.00	.00	33,826.00
	WATER TOTAL	659,750.00	12,630.23	61,961.66	9.39	597,788.34
	SANITATION TOTAL	124,002.00	919.30	16,079.99	12.97	107,922.01

TOWN OF HERMOSA
 BUDGET REPORT
 CALENDAR 5/2023, FISCAL 5/2023

ACCOUNT NUMBER	ACCOUNT TITLE	TOTAL BUDGET	PTD BALANCE	YTD BALANCE	PERCENT EXPENDED	UNEXPENDED
604 SEWER	DEBT SERVICE TOTAL	4,218.00	319.50	1,597.51	37.87	2,620.49
	SEWER TOTAL	128,220.00	1,238.80	17,677.50	13.79	110,542.50
	TOTAL EXPENSES	1,281,322.00	38,096.11	331,150.89	25.84	950,171.11



12 B.

Division of Planning & Engineering
Office of Local Government Assistance
700 E Broadway
Pierre, SD 57501
O: 605.773.3390
dot.sd.gov

April 21, 2023

Mr. Doug Wessel, PE
Brosz Engineering
3561 Whitewood Service Rd Suite A
Sturgis, SD 57785

RE: P NBIS(43), PCN 04N7
WORK ORDER BI-66-23, CITY OF HERMOSA

Dear Mr. Wessel:

Enclosed with this letter is a fully executed Work Order Number (BI-66-23) to be performed under the terms of Agreement Number 410863 between your firm and the South Dakota Department of Transportation.

The following provision applies to the work order executed by the parties involved in order to meet federal inspection requirements:

It is understood and agreed between the parties that certain work may have been performed by the consultant before this work order was approved. It is the intent of the parties that the consultant performs this work and be paid in accordance with the work order. In light of the foregoing, the parties hereto ratify the services of the consultant which may have been performed during the period of time between the Verbal Notice to Proceed date and the Notice to Proceed date which is the date of this letter. The parties agree that the consultant will be paid for the services which were performed in relation to the work order listed above and in accordance with the terms of Agreement Number 410863. The effective date of this notice is the date of the verbal Notice to Proceed April 21, 2023.

This letter will also serve as your Notice to Proceed with the work detailed in the Work Order.

Sincerely,

A handwritten signature in black ink, appearing to read "Cody Axlund". The signature is written in a cursive, flowing style.

Cody Axlund
LGA Lead Bridge Engineer

Enclosures

cc: Internal Audits
County/City
File

Axlund, Cody

From: Axlund, Cody
Sent: Monday, April 3, 2023 9:45 AM
To: Doug Wessel; Don Hammond
Cc: Axlund, Cody
Subject: 2023 Bridge Inspections (Scope) - City of Hermosa
Attachments: Hermosa.xlsx

TO: Brosz Engineering
FROM: Cody Axlund, SDDOT Local Government Assistance
PROJECT: P NBIS(43), PCN 04N7

The City of Hermosa has requested that your firm be employed to complete their bridge inspection work for 2023. Please prepare a breakdown of estimated costs required to accomplish this work and submit it to **SDDOT Local Government Assistance, c/o Cody Axlund**, for preparation of the work order under the State's retainer contract.

The following contains the number of structures to be inspected in 2023. The cost breakdown should include estimated travel, per diems, personnel wages, fixed fee, and any other costs associated with the inspections. Digital photography will once again be required. This summation will be the basis for the maximum limiting amount of the work order.

--Refer to the current Master Retainer Agreement for a complete list of technical requirements and provisions.

--All inspections must be performed no more than 30 days after the next inspection date in Bridge Management (BrM) and work submitted by November 1, 2023 unless a time extension has been authorized prior to the deadline. Inspections past due are subject to penalty according to the Retainer Agreement.

--All required submittals to SDDOT will be electronic and uploaded to BrM Multimedia. Consultants will also scan, if necessary, and upload existing plans, shop plans, or drawings for every structure where available that is inspected in 2023.

--A cross section must be performed and placed in file on all structures, excluding culverts and pipe, on the upstream side of bridge to monitor scour.

--Complete and update a Fracture Critical Inspection Form for all fracture critical structures.

--Complete and update a Critical Finding form and update BrM on structures with critical findings.

--Complete and update a Scour Plan of Action (POA) on all structures with Unknown Foundations or Scour Critical based on Item 113 in BrM.

--All structures with plans or that can be rated by field measurements must have a load rating performed and kept in the bridge file for the three (3) South Dakota legal load configurations and SHV's according to the Manual for Bridge Evaluation (MBE) and all revisions. Any structure needing a new rating will follow the SDDOT Load Rating Manual and include an electronic AASHTOWare Bridge Rating (BrR) model to be submitted to the Department.

--Structures within one road mile from the Interstate Highway System will also require load rating of the EV2 and EV3 vehicles. These must be rated if an analysis can be done by plans or field measurements.

--Update all National Bridge Elements (NBEs) and Bridge Management Elements (BMEs) according to the AASHTO Guide Manual for Bridge Element Inspection and all revisions. These will be updated in the Bridge Management Software.

--Consultants will have until January 1, 2024 to individually meet with each county commission or city council and go over inspection documents, load restrictions, and critical findings unless other arrangements are approved by this office.

--The bridge inspection Team Leader is required to be on location during all bridge inspections as per the criteria specified in 23 CFR 650.

Total Initial Inspections - 0

Total Re-Inspections - 1

Estimated Engineering Cost
Brosz Engineering, Inc.
P NBIS (43), PCN 04N7
City of Hermosa
Retainer Agreement Number: 410863

Direct Labor Salary Cost:	Estimated Hours	Hourly Rate	Estimated Cost
Don Hammond - Sr. Engineer I	4	\$66.00	\$264.00
Bruce Wilsey - Sr. Engineer Tech I	1	\$49.50	\$49.50
Zach Wilsey - Engineer Tech III	1	\$33.00	\$33.00
Total Direct Labor Cost	6		\$346.50
Labor Overhead Cost:		186.35%	\$645.70
Fixed Fee - Max. Allowable for <u>Bridge Inspections</u>		15.00%	\$148.83
Capital Cost of Money		0.626%	\$2.17
Direct Expenses:			
Mileage	0	\$0.00	\$0.00
Meals (Per Diem)	0	\$0.00	\$0.00
Lodging	0	\$0.00	\$0.00
Photocopies	0	\$0.00	\$0.00
Postage	0	\$0.00	\$0.00
Miscellaneous	1	\$56.80	\$56.80
Total Direct Expenses			\$56.80
Total Estimated Engineering Cost			\$1,200.00
Equipment Rental			\$0.00
Total Estimated Cost			\$1,200.00

APPROVED

Local Trans. Programs
 Date 4-18-23

Brosz Engineering 2023 Rates - SDDOT

Name	40 Hr/Wk	45 Hr/Wk	50 Hr/Wk
Don Hammond - Sr. Engineer I	\$ 60.00	\$ 63.33	\$ 66.00
Bruce Wilsey - Sr. Engineer Tech I	\$ 45.00	\$ 47.50	\$ 49.50
Zach Wilsey - Engineer Tech III	\$ 30.00	\$ 31.67	\$ 33.00

**WORK ORDER FOR CONSULTANT SERVICES
LOCAL GOVERNMENT PROJECTS**

DOT 917-B
04/05/2022

GENERAL

1 **Work Order No.** BI-66-23 2 **Agr. No.** 410863 3 **Date** 04/24/2023
 4 **Amendment No.**
 5 **Consultant** Brosz Engineering

PROJECT INFORMATION

6 **Project No.** P NBIS(43) 7 **PCIN** 04N7 8 **County/City** City of Hermosa
 9 **Project Description** Bridge Inspections
 10 **Project Location** Citywide
 11 **Work Type** Bridge Inspections

For Specifics on the Scope of Work, See Attachment I

12 MAXIMUM LIMITING AMOUNT	\$1,200.00	13 FIXED FEE	\$148.83
14 Amendment Amount		15 FIXED FEE	
16 New Maximum Limiting Amount	\$1,200.00	17 FIXED FEE	\$148.83
18 COMPLETION DATE	05/01/2024		

See Attachment I for Interim dates and deliverables.

CONTACT PERSONS

Consultant Doug Wessel, Brosz Engineering
City or County City of Hermosa Engineer or Finance Officer
SDDOT Cody Axlund, SDDOT

INSURANCE REQUIREMENTS

20 Type of Insurance	Expiration Date	On File
General Liability	09/01/2023	Yes
Automobile Liability	09/01/2023	Yes
Workers Compensation	09/01/2023	Yes
Professional Liability	09/01/2023	Yes

ATTACHMENTS

Services Required
 Reimbursement for Travel

APPROVAL BY:

Consultant: *[Signature]* **Date** 04/30/2023
City or County: *[Signature]* **Date** 05/01/2023
DOT: *[Signature]* **Date** 5/2/2023

DISTRIBUTION:
 (1) Original - Audits
 (1) Copy - Consultant
 (1) Copy - Local Government Agency
 (1) Copy - Originating Office

Bridge ID 17434018 County Owner 3 0.2 N OF HERMOSA Location 11/1/2023 12:00:00 AM Next insp 24 21.32 2021 1 Concrete 19 Culvert 1 Design mainspans 43.84275820000 lat gis 103.19099370700 long gis Good bridge condition

LB

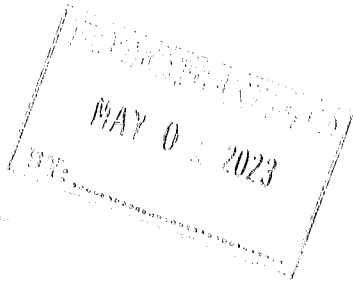

**DEPARTMENT of AGRICULTURE
and NATURAL RESOURCES**

JOE FOSS BUILDING
523 E CAPITOL AVE
PIERRE SD 57501-3182
danr.sd.gov

April 28, 2023

Ms Monika Serviss
Town of Hermosa
PO Box 298
Hermosa, SD 57744-0298

RE: Town of Hermosa Public Water System

Dear Ms Serviss:

Congratulations to you from DANR! The Town of Hermosa public water system has met the requirements of the Safe Drinking Water Act and the state of South Dakota's regulations for supplying safe drinking water to the public. For your efforts and concern for safe drinking water, we would like to present this achievement award to you. The Drinking Water Program has started this program to reward those systems and their certified operators that have demonstrated excellence in water system management and maintenance.

You will also find enclosed a draft press release concerning the award your system has received. The press release can be provided to your local newspaper and includes information about the award.

Thank you for your interest in maintaining safe drinking water for your consumers. If we can be of assistance to you, please contact us at (605) 773-3754.

Sincerely,

Mark S. Mayer, P.E.
Administrator
Drinking Water Program

Enclosure

FOR IMMEDIATE RELEASE: April 28, 2023

FOR MORE INFORMATION: Mark Mayer, (605) 773-3754

DANR RECOGNIZES TOWN OF HERMOSA FOR DRINKING WATER COMPLIANCE

PIERRE – Today the South Dakota Department of Agriculture and Natural Resources (DANR) announced that the Town of Hermosa public water system and the system's certified operators have been awarded a Drinking Water Certificate of Achievement Award. The award is for outstanding water system operations and environmental compliance with state drinking water standards for the past year.

"Access to safe and reliable water sources is essential to keeping our families safe and our economy growing," said DANR Secretary Hunter Roberts. "This award is a testament to the hard work and dedication of South Dakota's drinking water system operators and their efforts to ensure their customers have access to clean drinking water."

To qualify for the Drinking Water Certification of Achievement Award, public water systems and their system operations specialists had to meet all of the compliance monitoring and reporting requirements, drinking water standards, and certification requirements for 2022.

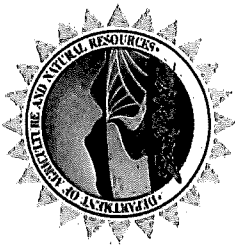

CERTIFICATE OF ACHIEVEMENT 2022

By virtue of the authority vested in me, and after due consideration, I do hereby certify that the

Town of Hermosa Public Water System

through extra concern and endeavor has met all federal and state requirements for safe drinking water
and has supplied safe drinking water to the public it serves.

A handwritten signature in black ink, appearing to read "Hort R.", is written over a horizontal line.

Secretary
Department of Environment and Natural Resources

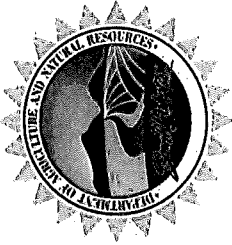

CERTIFICATE OF ACHIEVEMENT

2022

By virtue of the authority vested in me, and after due consideration, I do hereby certify that

Chuck Ferguson

through extra concern and endeavor has enabled the

Hermosa-Old System Public Water System

to meet all state requirements for safe drinking water
and has enabled this drinking water system to supply safe drinking water to the public they serve.

Secretary
Department of Environment and Natural Resources

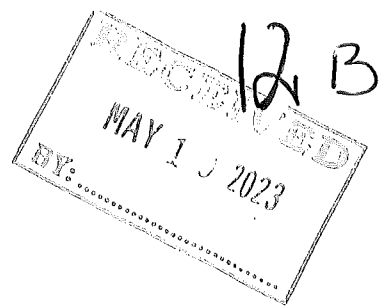

May 2, 2023

Town of Hermosa
Attn: Linda Kramer, Finance Officer
P.O. Box 298
Hermosa, SD 57744-0298

RE: Clean Water State Revolving Fund Hermosa C461278-01

Dear Mike,

The Loan Term for the above referenced transactions ended on April 24, 2023, and upon the final payment received on the loans on April 24, 2023. Since the indebtedness to the South Dakota Conservancy District on this loan has been met, the original Borrower Bond has been marked Paid and Cancelled, to be returned to you for your records.

It has been our pleasure working with you and the District during your financing.

Should you require any additional information, or if you have any questions or concerns, please do not hesitate to contact me at (206) 344-4607.

Sincerely,

A handwritten signature in black ink, appearing to read "Greg E. Skutnik", with a long horizontal line extending to the right.

Greg E. Skutnik
Vice President
(206) 344-4607 Telephone
(206) 344-4630 Facsimile

cc: Ms. Stephanie Riggle, SDCCD
Ms. Megan Johnson, SDCCD

Enclosure

12B.

From: Jill Dybvig
Sent: Wednesday, May 10, 2023 8:05 AM
To: Monika Serviss
Subject: FW: Town of Hermosa

From: Ron Vanderpool <rvanderpool@map-inc.org>
Sent: Tuesday, May 9, 2023 3:34 PM
To: Jill Dybvig <jill@hermosasd.com>
Cc: Kelli Fika <kfika@map-inc.org>; Kevin Coldsmith <kcoldsmith@map-inc.org>
Subject: RE: Town of Hermosa

Greetings Jill!

All good questions. I addressed each below right after your question.

Super excited you are rock and rolling with the LSLI solution. You are our poster girl!!! 😊

Do not hesitate to contact us if you have any questions!

Ronald Vanderpool
GIS Coordinator
307-996-6888

From: Jill Dybvig <jill@hermosasd.com>
Sent: Tuesday, May 9, 2023 2:30 PM
To: Ron Vanderpool <rvanderpool@map-inc.org>
Subject: Town of Hermosa

Ron,

Good afternoon! I have been working on filling in information in Lead Service Line Editor. If you get a chance can you look at it and let me know how I am doing?**[Ron Vanderpool] The map looks great. I think you are doing fine. When you open the LSLI Dashboard you can see 4 columns that are shaded blue. These are the must have columns for EPA. All the others are "strongly encouraged/recommended. Not sure if Mark wants more but you are filling out most of them so that is good.**

Also, I have a few questions-

1. What is the reason I am requesting the parcel data again from Custer County? What information do I need off of that?**[Ron Vanderpool] In Hermosa's case you have the addressing already figured out with your Excel document. I like the parcel data to use as a reference for property boundaries, parcel ID, types of uses, primary structure build dates, etc. The data you pull has all of that but it is one at a time as opposed to having the information in your map. I encourage systems to obtain the parcel layer from the assessor at least ever few years just to stay current. When you ask, if you do, make sure to mention the EPA mandate is the reason you need it, even if you don't. Might save some monies. The parcel data also helps delineate line locations referenced to right-of-ways, platted widths of streets, etc. All great information to have in a municipal mapping.**

2. I have been using the Utility Asset ID as the Distribution Main ID #. I hope that is correct.**[Ron Vanderpool]** No real right or wrong for the Asset ID ~ utility or customer. I personally leave it blank and would not use the DM -. It is just another way to identify the line for each side. If I was to enter anything in that field, I would make it reflect the LSLI data specifically. We can auto populate that information once you have the inventory completed.
3. Will we be adding and creating in the map the Customer Asset ID and the service line going to the home?**[Ron Vanderpool]** Once the initial inventory is complete, a service line feature could be drawn to connect curb stops/meter pits to the resident. If the system owned them, it would make sense to connect them. If not, then just the LSLI icon/marker is good enough.
4. What if I have different dates for water pipe installation. Lets say the home was built in 1950 but they added an addition in 1990?**[Ron Vanderpool]** The year the primary structure was built is important for statistically analysis, (educated assuming) of the service line material. Any data that you have which depicts the date of service line install is more important. Add the primary structure initial build date in the "Year Built" field and the service line install date in the appropriate utility/customer fields and do not work about additions, unless they were a substantial rebuild (like demo and start over).
5. The templates (circles for service lines) – the left side is utility.... And the right side customer? Should of asked this before I started 😊**[Ron Vanderpool]** You are 100% correct. I should have told you that. Since we were struggling, I probably forgot. Well done!
6. If I pick the wrong template circle can I change it?**[Ron Vanderpool]** Totally! As you remove the little dots based on the historical/record data you have, you can also change the color by changing the entry. Here is how it works; if you select Non-Lead in the Utility or Customer Material, the specific side of the icon turns Blue, Red for Lead, Yellow for Galvanized, and Gray for Unknown. The little dots (I call them eyeballs) go away when you select Utility/Customer Side Verified. This is done once you are a sure as possible about the true nature of each side of the service line. Then, when each is either verified or not verified (by selecting something in the "Verified" field, eyeballs go away, you go up to the "Entire Service Line Status" and mark it accordingly. The caveat to this is if either side is Lead, you select Lead in the field, or Galvanized Requiring Replacement (GRR) if one side or the other is GRR, or Unknown if either side is Unknown, or the best case scenario if both sides are none of the above then select Non-Lead. I see that you have filled many of these in.
7. If I can indicate that a home is built after 1986 just from the 2023 Custer County Assessment Book, is that good enough and I have been putting that in the Customer notes section?**[Ron Vanderpool]** I would say yes, with a little caution. 1986 is good Federally because that is when the Lead ban was entered into the Federal registry but many states did not get around to adopting until 1988. Remember, this is an initial inventory and planned by the Primacy/EPA to be a working document. Changes later are totally anticipated.
8. We have a map of our entire towns utility side where the water lines run. Do I need to include that attachment in every file to prove the utility side?**[Ron Vanderpool]** Absolutely not. We will just make notes of that in the overview template.
9. On the Customer side I have been attaching permits document that support when the home was built. Is that enough?**[Ron Vanderpool]** For sure and a great way to do it. You can, if you are sure that those records are going to be somewhere safe, perpetually, just reference that they are stored in the municipal archives in the same place as mentioned in question 7.

Sorry.... That's all have for now 😊

Thank you and have a great day!!!

12c.

Meter instalation expense - Parts only

	Price
3/4" M25 Low Lead Bronze Bare Meter	\$ 70.00
M25 Gallon 8 Dial HRE with 25' Twist tight wire	\$ 96.00
Remote Badger Touch Module	\$ 20.00
9" Twist tight;male by flying lead;endpoint side	\$ 12.00
4" AY Low Lead stright meter couplings with wire hole & gasket	\$ 11.50
3/4" Thick rubber meter gasket	\$ 0.16
Total expense for one meter	\$ 209.66

***Note: Contact us for any special events which may occur throughout the year.**

Payroll

Fire Department	\$0	_____
Sewer Department	\$0	_____
Waterworks	\$0	_____
Electric Utility	\$0	_____
Gas Utility	\$0	_____

Do You Have These Exposures To Be Covered Through SDPAA?

	#	
Ambulance Service - Number of Ambulances	0	_____
EMTs, Paramedics, Nurses	0	_____
Garbage Dump/Landfill/Refuse Site	0	_____
Swimming Areas - Pools	0	_____
<i>Diving Boards</i>	0	_____
<i>Flumes - Total length in feet</i>	0	_____
<i>Plunges</i>	0	_____
Fireworks Displays	0	_____
Golf Courses	0	_____
<i>Holes</i>	0	_____
Road Miles	6	_____
Fire Fighters - Number of Volunteers Excluding EMTs	0	_____
<i>Do the Volunteer Fire Fighters have separate coverage? (Y/N)</i>		_____
Zoos	0	_____
Bridges	1	_____ <u>1</u> _____
Dams	0	_____
Boats	0	_____
Daycare Children	0	_____
Public Health Department (Y/N)	N	_____
Airport (Y/N)	N	_____
Skateboard Parks	0	_____
Home Health Care Providers	0	_____
Campgrounds (Y/N)	N	_____
<i># of Sites</i>	0	_____
Gun/Archery Ranges (Y/N)	N	_____
<i>If yes, are ranges owned/operated by you? (Y/N)</i>	N	_____
4-H Coordinator (employed by you) (Y/N)	N	_____
Boards Operating Under Your Authority (Y/N)	N	_____
Special Events involving Alcoholic Beverages (Y/N)	N	_____
<i>Contact the SDPAA to obtain special event coverage for these events</i>		
Drone, owned and operated by your entity (Y/N)	N	_____

Additional Renewal Questions:

Enhanced Crime Coverage (Y indicates already enrolled)	Y	_____ <u>Y</u> <u>N</u> _____
--	---	-------------------------------

Have you hired an employee who had a prior theft or dishonest act involving loss of money, securities or other property valued over \$10,000? (Y/N) N _____

If you have knowledge of such prior theft or dishonest act, an incident involving that employee may be excluded for Crime coverage under the SDPAA Crime coverage. Contact the SDPAA to procure separate coverage on a case-by-case basis.

Are you responsible for water quality testing? (Y/N) N _____ Y ?

If so, please describe: _____

Are you responsible for water distribution to residents? (Y/N) N _____ Y ?

If so, please describe: _____

NEW Member-run operations or exposures: _____

Please describe: _____

*Hired, Leased or Borrowed Autos are included if you purchase auto liability coverage through SDPAA. This coverage will be added via endorsement on your general liability coverage if you do not purchase auto liability through SDPAA.

Automobile Liability

	Previous July 8, 2022	Effective July 8, 2023
Limit	\$3,000,000	_____
Deductible	\$0	_____
Uninsured/Underinsured Motorist Limits	\$100,000	
Medical Payments	\$5,000	
 Number of Vehicles		
Private Passenger, Police & Light/Medium Trucks (GVW 0-20,000 lbs - trucks only)	2	2 ?
Heavy Trucks, Fire, Dump, Ambulance (GVW 20,000-45,000 lbs - trucks only)	0	_____
Extra Heavy Trucks, Buses (GVW over 45,000 lbs - trucks only)	0	_____
Antiques, Snowmobiles, ATV/UTVs, FEMA Mobile Homes, etc.	0	_____
Motorcycles	0	_____
Trailers	1	1 ?
Golf Carts	0	_____
Total	3	3 ?

W.E.

SOUTH DAKOTA MUNICIPAL LEAGUE

2023 Budget Training

Pierre | June 21
Sioux Falls | June 28

Agenda

9:30 a.m. **Registration**

10:00 a.m. **Municipal Budget Training – Dollars and \$ense**
to *Rod Fortin*, Director of Local Government Assistance, Department of Legislative Audit
2:00 p.m.

- Budget and Appropriations
 - Who is responsible?
 - Why is it important?
- Budget Resources
 - Where can I find help?
- Budget Timeline
 - When do I have to start and finish?
- Budget vs. Cash
 - What is the difference?
- Budget Preparation
 - Details
- Adoption of Appropriation Ordinance
 - Reading, Passage, and Publication
- Budget Execution
 - Set-up in Accounting System
 - Maximum Authorization to Spend
 - Monitoring
 - Increasing
 - Year-end
- Future Budgets
 - Indicators
 - Flow
 - Reserves

* Noon Lunch Provided

SOUTH DAKOTA MUNICIPAL LEAGUE

Budget Training - Pierre

Wednesday, June 21, 2023

This one-day training will provide elected officials and finance officers with the tools they need to create and maintain the annual municipal budget. Attendees will learn about available resources, preparation and timelines for completion of the budget, on-going monitoring, contingency transfer and supplemental appropriation.

Agenda

Register Online

\$30 per person

Registration/refund deadline: June 7

Location

Ramkota Hotel
920 W Sioux Ave
Pierre, SD 57501

Other Opportunities

June 28, 2023 | Sioux Falls, Ramkota Hotel

12 F.



DIVISION OF LICENSURE & ACCREDITATION

LICENSURE & SAFETY: Health Protection | Licensure & Certification | Medical Cannabis
ACCREDITATION & REPORTING: Vital Records | Health Data & Reporting
Accreditation & Quality | Legal

May 1, 2023

Re: West Nile Prevention Funding Opportunity

Dear South Dakota Community and Tribal Leaders:

With mosquito season just around the corner, the Department of Health is pleased to announce the availability of West Nile virus (WNV) prevention grants once again. \$500,000 is available in 2023 to assist cities, counties, and tribes with their mosquito control efforts. Grant awards will range from approximately \$500 to \$20,000 depending upon the size of the population served and their historical number of human WNV cases. Since the program's inception, the state has funded millions of dollars in support of local control programs to combat West Nile Virus in South Dakota.

As you know, human West Nile Virus continues to present a very significant threat to public health in South Dakota. Since WNV first emerged on South Dakota in 2001, there has been 2,741 human cases and 48 deaths due to mosquito borne WNV.

To apply for the WNV Prevention grants, eligible South Dakota city, county, and tribal officials need to complete the application available on the department's website at: <http://westnile.sd.gov>. **Applications are due by June 1st** and funding awards will be available starting July 1st. If you have any questions about this funding opportunity, please don't hesitate to contact us at Julie.Ramsey@state.sd.us or by phone at 605-773-8107.

Thanks for all your efforts to control mosquitoes and prevent West Nile virus.

Sincerely,

A handwritten signature in cursive script that reads 'Kaitlin Thomas'.

Kaitlin Thomas
Administrator
Office Public Health Preparedness and Response



2023 South Dakota Department of Health West Nile Virus Prevention Funding Opportunity

1. City, County, Town or Name of Tribe

Name

2. Mailing Address

Address

Address 2

City/Town

State/Province

ZIP/Postal Code

3. Person Completing Application

Name

Phone Number

Email Address

* 4. Authorized Local Official (please list who will be responsible for signing the contract)

Name

Phone Number

Email Address

Email Address

5. Local Mosquito Control Program Manager

Name

Prev

Next

Powered by



SurveyMonkey

See how easy it is to [create a survey](#).

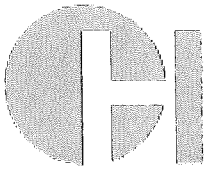

WEBSITE OF THE STATE OF SOUTH DAKOTA DEPARTMENT OF HEALTH
Melissa Magstadt, South Dakota Secretary of Health

MENU

[Home](#) ▶ [Diseases & Conditions](#) ▶ [Communicable and Infectious Diseases](#) ▶ [West Nile Virus](#)

[COVID-19 Updates and Information](#)

[West Nile Virus Prevention and Control](#)



If there's a way to prevent a viral infection that causes side effects that are at best uncomfortable and at worst life-threatening, **would you do your part?** [West Nile Virus \(WNV\)](#) is a very active illness in the state of South Dakota.

2023 WNV Grants

Hello South Dakota Community and Tribal Leaders:

With mosquito season just around the corner, the Department of Health is pleased to announce the availability of West Nile virus (WNV) prevention grants once again. \$500,000 is available in 2023 to assist cities, counties, and tribes with their mosquito control efforts. Grant awards will range from approximately \$500 to \$20,000 depending upon the size of the population served and the historical number of human WNV cases. Since the program's inception, the state has funded millions of dollars in support of local control programs to combat West Nile Virus in South Dakota.

As you know, the human West Nile Virus continues to present a very significant threat to public health in South Dakota. Since WNV first emerged in South Dakota in 2001, there have been 2,741 human cases and 48 deaths due to mosquito-borne WNV.

Applications are due by June 1st and funding awards will be available starting July 1st. Awards will be made on a reimbursement basis only for mosquito control expenditures between April 1, 2023, and October 31, 2023. All mosquito control equipment and supply purchases must be documented with appropriate receipts or invoices. Please note all eligible expenditures must be completed by October 31, 2023, and all requests for reimbursement must be completed by November 30, 2023. Total reimbursements will not exceed the amount of your total award. You will be notified of your award amount when the agreements are sent out for signature. Total award amounts will still be based on your jurisdiction's history of human West Nile virus cases and the latest population data.

Thanks for all your efforts to control mosquitoes and prevent West Nile virus. If you have any questions about this funding opportunity, please don't hesitate to contact us at Julie.Ramsey@state.sd.us or by phone at 605-773-8107.

*Kaitlin Thomas, SD-DOH
Office Public Health Preparedness and Response*

- [Online Application](#)

- [West Nile Invoice \(PDF\) - Download Word Document](#)

Access Resources

- [National Efforts to Fight West Nile Virus](#)
- [A History of West Nile Virus in South Dakota](#)
- [Sustainability in Mosquito Control](#)

Get educated on WNV facts and how to prevent the illness.



greatest number of
West Nile virus incidents

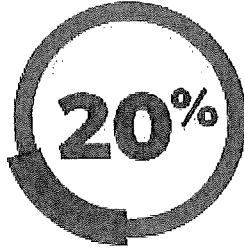

of infected develop fever,
other symptoms

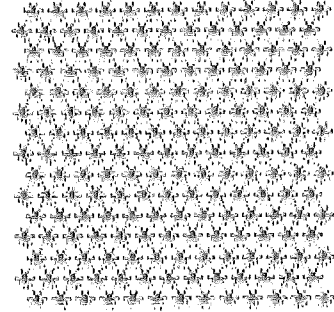

1 of 150
cases develop serious,
potentially fatal illness

Know the Facts

West Nile Virus is an infection most commonly spread through mosquito bites. While it is prevalent in many states with large mosquito populations, the rate of incidents is **highest in South Dakota**. And WNV can lead to many other symptoms, including fevers and even serious—potentially fatal—illness.

Know Your Risk

- [SDSU Extension Weekly Assessment & Mosquito Collection Data](#)
- [South Dakota West Nile Virus Fact Sheet](#)
- [How NASA is helping us fight West Nile](#)



SOUTH DAKOTA STATE
UNIVERSITY EXTENSION

Commercial Applicator Course

Certificate of Completion

This is to certify that

Monte Waltman

has completed

9 Public Health

Date

February 7, 2023



SOUTH DAKOTA STATE
UNIVERSITY EXTENSION

Commercial Applicator Course

Certificate of Completion

This is to certify that

Monte Waltman

has completed

Welcome

Date

January 23, 2023

Transportation

Doing
BusinessProjects &
StudiesPrograms &
Services

Travelers

Inside
SDDOT

TRANSPORTATION ECONOMIC DEVELOPMENT GRANTS

Home / Doing Business / Local Governments / Transportation
Economic Development Grants

The South Dakota Department of Transportation has developed a grant program to foster economic development and enhance community access in South Dakota. The program has three categorical purposes.

- The Industrial Park grants will be made to any local unit of government for the development of new or expanded access for new industry located within industrial parks. Applications are due April 15, July 15, or October 15.
- The Agri-Business grants will be made to any local unit of government for the development of new or expanded agri-business industries. Applications are due April 15, July 15, or October 15.
- Community Access Grants are state funds for towns less than 5,000 in population and are for the construction or reconstruction of major streets in each town such as Main Street, the road to the elevator, schools, hospitals, etc. Applications are due July 15.

These programs provide for 80% of the construction costs of the project, not including engineering or utility work. Grant size is limited to \$600,000 for Community Access and Agri-Business Grants and \$500,000 for Industrial Park Grants.

Application Should Include

+ Certification & Accreditation

+ Contractors

+ Engineering/Design Services

+ Environmental

- Local Governments

About Local Governments

Bridge Improvement Grants

City/County Fund Balances

Emergency Relief (ER)

Federal Bridge Program

Forms & Documents

Secure Accounts Billing

Transportation Economic Development
Grants

Urban Systems

Rural Access Infrastructure Fund Program

TALK TO US

[Transportation](#)[Doing
Business](#)[Projects &
Studies](#)[Programs &
Services](#)[Travelers](#)[Inside
SDDOT](#)

Project Requirements

- Designed in accordance with the South Dakota Department of Transportation [Standard Specifications for Roads and Bridges](#)
- Must comply with the American's with Disabilities Act
- Funds cannot be used for routine maintenance
- Must have plans and specifications stamped by a registered professional engineer

All grants will be based on the criteria developed by the Department of Transportation. The expenditure authority for the program will be determined by the Transportation Commission. All grants must be approved by the Transportation Commission and may be used to construct or reconstruct roads and streets in the community.

All aspects of these grant programs are outlined in the Fact Sheets and Policies for Industrial Park, Agri-Business Access, and Community Access Grant Programs.

- [Economic Development Grant Application](#)
- [Community Access Road Grant Fact Sheet](#)
- [Agri-Business Road Grant Fact Sheet](#)
- [Industrial Park Road Grants Fact Sheet](#)
- [Transportation Economic Development Grant Program Guide](#)
- [Community Access Grant Evaluation Form](#)

Contact

Paula Huizenga

Grants Program Engineer

605-773-6253

APPLICATION FOR INDUSTRIAL PARK, AGRI-BUSINESS ACCESS, OR COMMUNITY ACCESS GRANT FUNDS

APPLICATION FOR:

INDUSTRIAL PARK/ AGRI-BUSINESS
(Check one)

COMMUNITY ACCESS

APPLICANT AND ADDRESS:
(Include unit of government)

PROJECT LOCATION:

PROJECT DESCRIPTION:

THE APPLICANT CERTIFIES THAT:

To the best of my knowledge and belief, the information in this application is true and correct. The document has been duly authorized by the governing body of the applicant and the applicant will comply with all appropriate requirements if approved.

Name and Title (typed) Phone

Signature Date

APPLICATION PREPARED BY:

Name and Title (typed) Phone

Representing Date

Name of Consultant (typed) Phone

Representing Date

INDUSTRIAL PARK AND AGRI-BUSINESS ACCESS GRANTS

1. BUSINESSES TO BE SERVED AND PROPOSED EXPANSION PLAN:

2. COSTS OF INFRASTRUCTURE

NON PARTICIPATING ITEMS		PARTICIPATING ITEMS	
LAND		CONSTRUCTION	
UTILITIES		CONTINGENCIES	
ENGINEERING			
OTHER			
TOTAL		TOTAL	

3. FUNDING OF PROJECT

LOCAL	
OTHER	
DOT (80% as per project type)	

4. TOTAL NUMBER OF NEW FULL TIME EQUIVALENT JOBS TO BE CREATED:
(MINIMUM OF 5)

FULL TIME _____ PART TIME _____

5. TOTAL EMPLOYMENT FOR ALL FACILITIES OR DEVELOPMENT:
(MINIMUM OF 50 FOR INDUSTRIAL PARKS)

FULL TIME _____ PART TIME _____

6. TOTAL NEW CAPITAL INVESTMENT FOR THE FACILITY: _____

7. PROJECT LENGTH _____

8. ROW: Is the Right-of-Way dedicated to public use? yes _____ no _____

9. MAINTENANCE: Who will assume maintenance of the road upon project completion? _____

Attach the following to the application:

- Map showing the location of the project
- Typical Section
- Cost estimate prepared by engineer
- Resolution of Support from the City Council or County Commission
- Letters of Commitment from industries involved in creating new or existing employment.

COMMUNITY ACCESS GRANTS

1. PROJECT TITLE:
(Town, streets, project termini)

2. PROJECT INFORMATION:

Project Length _____ Population _____

Existing roadway width _____ No. of businesses effected _____

Existing surfacing type _____ Is there a current state grant/loan associated with this project? _____

Average Daily Traffic _____ Percent Trucks _____

Future maintenance is to be performed by: _____

Area of community to be served: indicate locations of schools/businesses, etc. (include a map) _____

Current roadway condition (general description) _____

3. PROJECT COSTS

NON PARTICIPATING ITEMS		PARTICIPATING ITEMS	
UTILITIES		CONSTRUCTION	
ENGINEERING		CONTINGENCIES	
OTHER			
TOTAL		TOTAL	

TOTAL PROJECT COST _____

4. FUNDING OF PROJECT:

LOCAL	
OTHER	
DOT (80% OF PARTICIPATING ITEMS)	

Attach the following to the application:

- Map showing the location of the project
- Typical Section
- Cost estimate prepared by engineer
- Resolution of Support from the City Council or County Commission



DEPARTMENT OF TRANSPORTATION

COMMUNITY ACCESS ROAD GRANTS FACT SHEET

WHAT

The Department of Transportation Community Access Program is a means for small towns to pave or reconstruct important local roads such as their Main Street, the road to the elevator or schools, etc.

- Grant amount is a maximum of \$600,000.
- State reimburses local sponsor for 80% of construction costs.
- The community is responsible for all right-of-way acquisitions, utility costs, and design and construction engineering costs.
- The community is responsible to let the project to bid.

WHO

Town must be less than 5,000 in population in order to be eligible for these grant funds. The application must be submitted by a local government. Applications are ranked by the Office of Local Government Assistance. The rankings are based on a variety of factors including existing road condition, average daily traffic and truck traffic, location, if the project is to be combined with an infrastructure project such as water/sewer/storm and has other infrastructure funding available such as Community Development Block Grant, State Revolving Loan Fund or Consolidated Water Facilities Construction Fund, the impact on businesses, etc.

WHEN

Grant application notices are sent out in the spring of each year. Applications are due to the Department by July 15. In the fall of each year the Transportation Commission receives a list of ranked application for approval.

APPLICATIONS

Applications are available through the Office of Local Government Assistance in the Department of Transportation. For a copy of the policy and application forms call (605) 773-6253, or check out our website at dot.sd.gov under "Forms".

CRITERIA FOR EVALUATION OF APPLICATIONS

Applications will be rated and scored against each of the following factors. All points for each factor will be rounded to the nearest whole number. The maximum score possible is 320 points (220 based on "Evaluation of Need," 50 based on "Impact on Businesses" and 50 based on "Program Factor").

A. EVALUATION OF NEED

1) Existing Condition (90 Points). All applications are compared in terms of existing road/street condition. Surfacing Condition, Drainage Problems and Safety problems.

a) SURFACING (30 Points)

Flexible Pavement (Asphalt):

Condition	POINTS	
	Possible	Awarded
Excellent: Hairline Cracks - Minor Depressions	(0-5)	
Very Good: Low to Medium cracking, but cracks are generally very tight.	(5-10)	
Good: Cracks are 1/4" to 1/2" wide, some alligator cracking and rutting.	(10-15)	
Fair: Medium to high severity of alligator cracking and rutting. Cracks are generally 1/2" wide.	(15-20)	
Poor: Severe Alligator Cracking and rutting, pieces of asphalt are missing and potholes are present.	(20-25)	
Failed: Traffic Operation is Difficult. Potholes and alligator cracking are extensive. Rut depth exceeds 3/4".	(25-30)	

Concrete Pavement:

Condition	POINTS	
	Possible	Awarded
Excellent: Isolated Hairline Cracks	(0-5)	
Very Good: Up to 25 ft of cracking per 1000 S.F. of pavement. Cracks are generally tight but some may be as much as 1/4" wide.	(5-10)	
Good: 25-75 ft of cracking per 1000 S.F. of pavement some spalling and faulting along cracks and joints.	(10-15)	
Fair: Presence of cracks, patches, and spalling is common. Transverse joint faulting is quite evident.	(15-20)	
Poor Condition: Shattered slabs are common, transverse joint faulting is very evident.	(20-25)	
Failed: Traffic operation is difficult and Maintenance is inappropriate.	(25-30)	

Gravel Surface:

Condition	POINTS	
	Possible	Awarded
Very Good: The only distress is dusting in dry conditions.	(0-10)	
Good: Medium-severity loose aggregate, low-severity washboarding, and some slight rutting.	(10-15)	
Fair: Moderate washboarding over 10-25% of area, moderate rutting, small potholes, and some loose aggregate	(15-20)	
Poor: Little or no roadway crown, severe washboarding and loose aggregate, moderate potholing, 25% of road has little or no aggregate.	(20-25)	
Failed: Travel on road is very difficult. No crown or bowl-shaped road. Severe rutting and potholing many areas have little to no aggregate.	(25-30)	

b) Drainage (30 Points)

Condition	POINTS	
	Possible	Awarded
<u>Rural Section:</u> Water stands in ditch - allows cat tails to grow		
<u>Urban Section:</u> Inadequate or non-existent storm sewer, Inadequate or non-existent curb and gutter	(0-10)	
Water collects in ruts and low spots on the road.	(0-10)	
Other: Major Drainage structure in poor condition, frequent flooding (2-3 year occurrence), etc.	(0-10)	
DRAINAGE TOTAL	(0-30)	

c) Safety (30 Points)

Condition	POINTS	
	Possible	Awarded
Adequate	0	
Dangerous Intersection(s)	(0-10)	
Substandard Roadway Width	(0-10)	
Poor visibility	(0-10)	
SAFETY TOTAL	(0-30)	

A project which consists of a new alignment shall receive forty-five (45) points.

	GRAND TOTAL	90	
--	--------------------	----	--

C. PROGRAM FACTOR-IMPACT OF THE PROPOSED PROGRAM (50 points)

This factor will take into consideration the items that do not fall under any other rating factor. The following items will be considered:

- Is this phase 2 or more of a multiple phase project?
- Is the project tied to other projects or phased in order for the community to afford the project?
- What is the rate of deterioration of the street? Will it last for one or two more grant cycles without total deterioration occurring?
- Is it a cooperative project between multiple agencies (state-county-city-township-tribe)?
- Is the project cost effective--will the cost of the fix to the street be justifiable compared to the increase/decrease in population/businesses/industry etc.?

All projects are compared in terms of impact on the identified areas and awarded points from 0 to 50 in 10-point increments.

D. PREVIOUS GRANT AWARDS (- 50 points)

Applicant awarded a Community Access Grant within the past 5 years?

Yes: - 50 points

12 H.

WATER & WASTE FUNDING IN SOUTH DAKOTA

ENVIRONMENTAL FUNDING RESOURCES

[Program Information](#) ▾

[Water Reports](#) ▾

[Water & Waste Funding Forms](#) ▾

Clean Water State Revolving Fund

The Clean Water State Revolving Fund (SRF) Program was established to provide low interest loans to governmental entities for clean water and non-point source pollution control projects. The amount of funds available is dependent upon the amount of appropriations from the U.S. Congress and the amount of repayments from funds previously loaned.

Eligibility Requirements

In order to be eligible for the Drinking Water SRF program, the applicant must be: 1) a governmental entity with the authority to generate revenues and to repay either a general obligation, revenue obligation, sales tax obligation, or combination of these bonds or 2) a non-profit corporation with the authority to generate revenues and repay a loan. The project must be on the State Water Plan prior to submitting the funding application.

The project must be on the State Water Plan prior to submitting the funding application.

The project/activity must be identified and included as a potential project in the **Intended Use Plan (IUP)**. The IUP identifies potential drinking water projects. The list of potential projects incorporates a priority ranking system to comply with **Project Priority List** requirements as per federal regulations.

Application Deadlines

Applications must be postmarked or received on or before the first day of January, April, July, and October. The department will present applications to the board after the required technical review and financial analysis have been completed. The department will notify applicants of the date for the board meeting at which applications will be considered by the board.

Award Dates

The department will notify applicants of the date for the board meeting at which applications will be considered by the board. Board meeting dates are public noticed and available on the DANR website.

Interest Rates and Terms

The board sets **interest rates** for the program and makes adjustments to the rates on an as-needed basis. By Administrative Rule, it is required that to amend the interest rates they must be included as part of the posted board meeting agenda. Borrowers meeting the criteria of a disadvantaged community may be eligible for reduced interest rates and a term up to 30 years. Municipalities, intermunicipal and interstate agencies may be eligible for extended term financing for 21-30 years.

Award Criteria

The board awards Clean Water SRF loans by considering the following:

- The availability of funds in the Clean Water SRF program;
- The applicant's need;
- Violation of health and safety standards; and
- The applicant's ability to repay.

Application Requirements

Clean Water SRF applications must include the entity's most recent audited financial statements or unaudited annual reports. This financial information must include a detailed break-down of the revenue fund pledged toward repayment of the loan.

Bond counsel must be retained when the application is submitted to the department. Bond counsel will prepare the loan documents for the applicant, as well as the necessary resolutions and ordinances including the resolution for the board to approve the loan. An opinion will be issued by bond counsel on the applicant's ability to issue the Clean Water SRF debt.

Green Project Reserve

Water and wastewater projects that address green infrastructure, water or energy efficiency improvements, or other environmentally innovative activities are being sought for funding from the State Revolving Fund (SRF)

programs. These four categories of projects are collectively referred to as the **Green Project Reserve** or "green projects."

Facilities Planning Process

A **Clean Water Facilities Plan** must be prepared and submitted as part of the Clean Water SRF application. The facilities plan documents the studies and plans required of treatment works under the Clean Water Act. Clean Water SRF staff review the facilities plan and prepare an environmental review document. The public and several review agencies are involved in the facilities plan process, making this process time-consuming for the applicant and the department.

Facilities planning investigates the need for proposed facilities through a systematic evaluation of alternatives that are feasible in light of the unique demographic, topographic, hydrologic, and institutional characteristics of the area; and demonstrates that the selected alternative is cost effective.

A facilities plan must describe both the proposed treatment works and the complete collection system of which it is a part.

A facilities plan must also include adequate information to complete an environmental review.

The agencies listed in the facilities plan document must be given the opportunity to review and comment on the proposed project. After these items are addressed, the department will issue an environmental review to the applicant to publish in a local newspaper. The Board of Water and Natural Resources will consider a loan application after the publication of the environmental review.

The facilities planning process requires a public hearing. A "Notice of Public Hearing" should be published at least 10 days prior to the hearing. The publication shall include a description of the project, the amount of SRF loan to be borrowed, and the interest rate and term of the loan. Minutes must be kept at the public hearing and should include a summary of any comments received on the proposed project. A copy of the affidavit of publication and meeting minutes must be submitted as part of the final Facilities Plan.

Rules and Regulations

Rules and regulations concerning the Drinking Water SRF Program may be found in the Administrative Rules of South Dakota **74:05:08** and the federal Clean Water Act. Documents related to **unemployment rate** and **median household income** are referenced in the rules. For copies of these rules or the Act, you may contact:

Department of Environment and Natural Resources
Division of Financial and Technical Assistance
Joe Foss Building
523 East Capitol
Pierre, South Dakota 57501
Phone: (605) 773-4216
Fax: (605) 773-4068
Email: [Mike.Perkovich](mailto:Mike.Perkovich@dnr.sd.gov)

Contact Us

Department Secretary:
Hunter Roberts

📍 523 E Capitol Ave,
Pierre, SD 57501-3182

📞 605-773-5559

✉️ [Email DANR](mailto:Email.DANR)

DANR Links

[About DANR](#)
[Contact Us](#)
[State Fair](#)
[Press](#)
[Nondiscrimination Policy](#)
[Nondiscrimination Complaint Form](#)
[DANR Intranet Site](#)

State Links

[State Home Page](#)
[Disclaimer](#)
[Accessibility](#)
[Privacy Policy](#)

Follow Us



ENVIRONMENTAL FUNDING

ENVIRONMENTAL FUNDING RESOURCES

[Program
Information](#) ▾

[Water
Reports](#) ▾

[Water &
Waste
Funding
Forms](#) ▾

Drinking Water Project Funding

The Department of Agriculture and Natural Resources is committed to improving and maintaining the drinking water infrastructure throughout the state. Grants and low-interest loans offered through the Board of Water and Natural Resources are available for these purposes.

Funding Sources

Funding for drinking water projects is provided through the [Drinking Water State Revolving Fund](#) program and the [Consolidated Water Facilities Construction Program](#). Applicants should expect to receive some portion of funding as a loan from the Drinking Water SRF program. As a result, applicants must satisfy all requirements associated with the Drinking Water SRF program.

State Water Plan

Drinking Water projects requesting funding must be on the [State Water Plan](#). [State Water Plan applications](#) must be postmarked or received at the Department of Agriculture and Natural Resources on or before the first day of October. Applications for amendment onto the State Water Facilities Plan are considered on a quarterly basis and must be postmarked or received by the department on or before the first day of February, May and August. A preliminary engineering report or facilities plan must accompany the application.

Large costly water projects that are seeking significant state cost share participation must be identified on the [State Water Resources Management System](#) portion of the State Water Plan. Often these projects require significant federal financing and may require federal authorization. These projects normally require several years to be completed. Projects are placed onto the State Water Resources Management System by the Legislature and the Governor based on recommendations made by the Board of Water and Natural Resources. Projects that have been placed on the State Water Resources Management System remain on the list until removed by the Legislature.

Small Community Planning Grants

Communities of 2,500 or less can receive a [Small Community Planning Grant](#) to assist in the preparation of a preliminary engineering report or facilities plans. [Small Community Planning Grant applications](#) can be submitted at any time.

Eligibility Requirements

In order to be eligible for drinking water funding, a project must:

1. Be included on the State Water Facilities Plan prior to the application deadline; and
2. Be sponsored by one of the following entities: a special purpose district that has the authority to construct a water resources project; a state agency or general purpose government such as a municipality, county, or township; a federally recognized Indian tribe; or a nonprofit corporation.

Very Small System Compliance Grant

Water systems with 50 or less connections and not-for-profit, non-transient non-community water systems can receive a [Very Small System Compliance Grant](#) to assist water systems that are in violation of the Safe Drinking Water Act to achieve compliance. Very Small System Compliance Grant applications can be submitted at any time.

Eligibility Requirements

A capacity review or sanitary survey should be completed by the Drinking Water Program prior to submission of the grant application in order to identify and support the need of the project.

Examples of eligible projects may include, but are not limited to:

- Installation or rehabilitation of a well in order to meet current or future Safe Drinking Water Act requirements, excluding the Total Coliform Rule.
- Compliance issues that are not solely related to capacity.
- Systems that have a significant deficiency or existing violations, or non-compliance and deficiency not corrected within said amount of time.
- Significant deficiency for ancillary equipment.
- Pilot studies related to equipment and new system installations.

Application Deadlines and Award Dates

[Drinking water project applications](#) are considered on a quarterly basis and must be postmarked or received by the department on or before the first day of January, April, July, and October. The department will notify applicants of the date for the board meeting at which applications will be considered by the board. Board meeting dates are public noticed and available on the SD Boards and Commissions website.

Additional Subsidy Grants and Principal Forgiveness

Applicants that meet the minimum established residential water rates may receive a grant or loan principal forgiveness. Adoption of minimum monthly utility rates provides no guarantee of an applicant receiving additional subsidy.

The minimum monthly residential water rates necessary for an applicant to be eligible for additional subsidy are \$30 based on 5,000 gallons usage for municipalities and sanitary districts and \$55 based on 7,000 gallons usage for all other applicants.

Grant assistance may be awarded to applicants not meeting the minimum established rates for economic development opportunities, expansion into new areas, regionalization or consolidation of facilities, or other unique situations that may require special consideration.

The minimum rates are established in sections Administrative Rules of South Dakota [74:05:07:01\(12\)](#) and [74:05:11:01\(21\)](#).

Interest Rates and Terms

The board sets **interest rates** for the program and makes adjustments to the rates on an as-needed basis. By Administrative Rule, it is required that to amend the interest rates they must be included as part of the posted board meeting agenda. Borrowers meeting the criteria of a disadvantaged community may be eligible for reduced interest rates and a term up to 30 years. Municipalities, intermunicipal and interstate agencies may be eligible for extended term financing for 21-30 years.

Drinking Water SRF Program Requirements

Financial Statements/Annual Reports - the applicant must submit the most recent audited financial statements or unaudited annual reports. This financial information must include a detailed break-down of the revenue fund pledged toward repayment of the loan.

Capacity Assessments - the Safe Drinking Water Act prohibits the department from loaning funds to water systems that do not have the technical, managerial, and financial capacity to operate the system, unless the intended project will address the capacity deficiency. Applicants with an existing public water system are required to complete the capacity assessment worksheets. The completed capacity assessment must be included as part of the application.

Bond/Legal Counsel - A political subdivisions must retain bond counsel and non-profit entities must retain legal counsel when the application is submitted to the department. Bond counsel and legal counsel will prepare the loan documents for the applicant and all necessary resolutions and ordinances. An opinion will be issued by bond counsel or legal counsel on the applicant's ability to incur Drinking Water SRF debt.

Facilities Planning Process - A **Drinking Water Facilities Plan** must be prepared and submitted as part of the Drinking Water SRF application. This is an engineering evaluation that describes the need for the proposed supply, treatment, storage, or distribution project based on present conditions and future needs; evaluates the costs and adequacies of appropriate alternatives; identifies potential environmental impacts of the proposed project; and provides the selection and justification of a final alternative;

Several state and federal agencies must be given the opportunity to review and comment on the proposed project. These agencies are SD Game, Fish and Parks, US Fish and Wildlife Service, USDA Natural Resources photo of water tower construction Conservation Service, US Army Corps of Engineers, SD State Historic Preservation Office.

The facilities planning process requires a public hearing. A "Notice of Public Hearing" should be published at least 10 days prior to the hearing. The publication shall include a description of the project, the amount of SRF loan to be borrowed, and the interest rate and term of the loan. Minutes must be kept at the public hearing and should include a summary of any comments received on the proposed project. A copy of the affidavit of publication and meeting minutes must be submitted as part of the final Facilities Plan.

Funding for Drinking Projects of \$250,000 or Less

Drinking water projects with a total cost of \$250,000 or less may apply using the **Small Water Facilities Funding application**. These applicants are not subject to the Drinking Water SRF program requirements.

Funding for Drinking Projects That are Not Eligible for Drinking Water SRF Loan

Drinking water projects that are not eligible for a Drinking Water SRF loan may also apply using the **Small Water Facilities Funding application**. Common examples of projects not eligible for a Drinking Water SRF loan are new water systems, projects intended primarily for fire protection or future growth, and projects that provide water for industrial applications.

Rules and Regulations

Rules concerning the **Consolidated Water Facilities Construction Program** may be found in the Administrative Rules of South Dakota [74:05:07](#). Rules and regulations concerning the Drinking Water SRF Program may be found in the Administrative Rules of South Dakota [74:05:11](#) and the federal Safe Drinking Water Act. For copies of these rules or the Act, you may contact:

Department of Agriculture and Natural Resources
Division of Financial and Technical Assistance
Joe Foss Building
523 East Capitol

Pierre, South Dakota 57501

Phone: (605) 773-4216

Fax: (605) 773-4068

Email: [Mike Perkovich](mailto:Mike.Perkovich)

Contact Us

Department Secretary:
Hunter Roberts

📍 523 E Capitol Ave,
Pierre, SD 57501-3182

📞 605-773-5559

✉️ [Email DANR](#)

DANR Links

[About DANR](#)

[Contact Us](#)

[State Fair](#)

[Press](#)

[Nondiscrimination Policy](#)

[Nondiscrimination Complaint Form](#)

[DANR Intranet Site](#)

State Links

[State Home Page](#)

[Disclaimer](#)

[Accessibility](#)

[Privacy Policy](#)

Follow Us



ENVIRONMENTAL FUNDING

Small Community Planning Grant

The Small Community Planning Grant Program was established to promote a proactive approach to water and wastewater infrastructure management. This program provides small communities with funds to hire an engineering consultant to develop a project specific engineering report. The engineering report's level of detail will be on par with the facilities plan required for SRF projects.

Eligibility Requirements

The grant is available to systems serving a population of 2,500 or fewer. The project sponsor must be an entity of government (county, municipality, or township), or a special purpose district with the authority to construct a water or wastewater project (sanitary, water user, watershed, or water project). Nonprofit organizations are also eligible provided they were formed for the primary purpose of supplying water or sanitary service. Nonprofit water systems applying for this grant must meet the definition of a community water system (a public water system which serves at least 15 service connections used by year-round residents or regularly serves at least 25 year-round residents). This grant is not available for projects already on the State Water Plan. Grants will be made on a first come, first served basis.

Application Requirements

An applicant must submit an original application to the Department of Environment and Natural Resources. The application will be reviewed by staff for completeness and technical merit. Staff will work with applicants to correct any identified deficiencies. The application is available for download or to complete online:

[Download form](#)

[Online form](#)

Award Dates

The Department of Environment and Natural Resources may make a small community planning grant award at any time following department review of the application.

Award Criteria

Communities will be reimbursed 80% of the cost of the engineering study upon completion of the engineering report. The maximum reimbursement a community may receive is \$8,000 for a water engineering study. Wastewater related studies may receive reimbursement up to \$10,000.

The remaining cost will be paid by the community and may consist of local cash or other non-state grant assistance. In-kind contributions will not be accepted as local match.

The engineering will be considered complete and payment made to the grantee only if all the items discussed in the Report Requirements section are addressed. The department will determine completeness of the study.

Report Requirements

The engineering study must contain adequate information to be used as a facilities plan. An outline of items that must be included in a facilities plan is located in the Small Community Planning Grant application. A professional engineer licensed in the state of South Dakota must prepare the study.

Department of Environment and Natural Resources
Division of Financial and Technical Assistance
Joe Foss Building
523 East Capitol
Pierre, South Dakota 57501

Phone: (605) 773-4216

Fax: (605) 773-4068

Email: [Mike Perkovich](mailto:Mike.Perkovich@nd.gov)

ENVIRONMENTAL FUNDING RESOURCES

Program

m

Information ▾

Water

Report

s ▾

Water
&
Waste
Fundi
ng
Forms



Contact Us

Department Secretary:
Hunter Roberts

📍 523 E Capitol Ave,
Pierre, SD 57501-3182

📞 605-773-5559

✉ [Email DANR](#)

DANR Links

[About DANR](#)

[Contact Us](#)

[State Fair](#)

[Press](#)

[Nondiscrimination Policy](#)

[Nondiscrimination Complaint Form](#)

[DANR Intranet Site](#)

State Links

[State Home Page](#)

[Disclaimer](#)

[Accessibility](#)

[Privacy Policy](#)

Follow Us





UNITED STATES ENVIRONMENTAL PROTECTION AGENCY
WASHINGTON, D.C. 20460

OFFICE OF WATER

March 30, 2023

MEMORANDUM

SUBJECT: FY 2023 Clean Water State Revolving Fund Base Allotment Availability

FROM: Radhika Fox
Assistant Administrator

A handwritten signature in black ink, appearing to be "Radhika Fox", written over a horizontal line.

TO: Regional Water Division Directors, Regions I-X

This memorandum provides FY 2023 Clean Water State Revolving Fund (CWSRF) allotments for states, tribes, and territories for funding provided through the Consolidated Appropriations Act, 2023 (PL.117-328). Terms and conditions will be available to the EPA Regions on the EPA SRF SharePoint site.

When combined with the funding provided by the Infrastructure Investment and Jobs Act (PL 117-58), also referred to as the Bipartisan Infrastructure Law (BIL), over \$3.2 billion will be provided to the CWSRF in fiscal year 2023 to assist states, tribes, and territories with infrastructure projects that help provide clean water to communities across the United States. This sustained level of funding reflects the Administration's commitment to strengthen the nation's wastewater and stormwater systems, while also providing significant resources for mitigating nonpoint source pollution and improving energy and water efficiency through targeted investments. It also reinforces the ability of the CWSRF program to address the priorities established in the BIL Implementation Memorandum of March 8, 2022, including increasing investment in disadvantaged communities, building wastewater systems' resilience to all threats, and supporting American workers and domestic manufacturing. Learn more about water infrastructure investments through the BIL.

The base allotment amounts reflect the appropriation of \$1,638,861,000 reduced by the funds directed by Congress towards Community Project Funding/Congressionally Directed Spending projects. Therefore, the amount of funds available to the base CWSRF program this year is \$775,752,358. Attached are the allotments, along with the required additional subsidy and Green Project Reserve amounts. A consolidated chart showing final 2023 BIL and base 604(b)¹ grant amounts is also included.

General information on the SRF programs can be found at <https://www.epa.gov/cwsrf>. Per the Clean Water Act (CWA), states must provide at least a 20 percent match to the capitalization grant amount.

¹ Section 604(b) of the Clean Water Act provides approximately 1% of CWSRF allotments for water quality management planning grants.

2023 Base Additional Subsidy Provisions

Two distinct and additive subsidy authorities are included in the base 2023 capitalization grant.

1) Congressional Additional Subsidy Authority

Under this authority, states may provide this subsidy to *any CWSRF-eligible recipient*. States must use 10 percent of the funds made available in the base 2023 CWSRF capitalization grant to provide additional subsidization to eligible recipients in the form of forgiveness of principal, negative interest loans, or grants (or any combination of these) to be used where such funds are provided as initial financing for an eligible recipient or to buy, refinance, or restructure the debt obligations of eligible recipients only where such debt was incurred after December 29, 2022.

2) Clean Water Act Additional Subsidy Authority

As amended by BIL (PL. 117-58), the CWA mandates that states use at least 10 percent but no more than 30 percent of the capitalization grant amount to provide additional subsidy to the following:

- any municipalities that meet the state's affordability criteria;
- municipalities that do not meet the state's affordability criteria but seek additional subsidization to benefit individual ratepayers in the residential user rate class; or
- entities that implement a process, material, technique, or technology that addresses water or energy efficiency goals; mitigates stormwater runoff; or encourages sustainable project planning, design, and construction.

Additional subsidy provided from this authority may be in the form of forgiveness of principal, grants, negative interest loans, other loan forgiveness, and through buying, refinancing, or restructuring debt.

If you have questions, contact Mark Mylin at Mylin.Mark@epa.gov.

Attachments

cc: Clean Water SRF Regional Branch Chiefs & Regional Coordinators, Regions I-X
Andrew Sawyers, Director, Office of Wastewater Management
Raffael Stein, Director, Water Infrastructure Division
Leo Gueriguian, Associate Director, Water Infrastructure Division
Michael Deane, Chief, State Revolving Fund Branch

FY 2023
Distribution of Clean Water SRF Appropriation
2023 Consolidated Appropriations
Base CWSRF Allotment of \$775,752,358*

State	CWSRF Allotment			State	CWSRF Allotment		
	Total Allotment	604(b) Grant**	Capitalization Grant		Total Allotment	604(b) Grant**	Capitalization Grant
Alabama	\$8,473,000	\$85,000	\$8,388,000	New Jersey	\$30,963,000	\$310,000	\$30,653,000
Alaska	\$4,535,000	\$45,000	\$4,490,000	New Mexico	\$3,720,000	\$37,000	\$3,683,000
Arizona	\$5,118,000	\$51,000	\$5,067,000	New York	\$83,628,000	\$836,000	\$82,792,000
Arkansas	\$4,957,000	\$50,000	\$4,907,000	North Carolina	\$13,675,000	\$137,000	\$13,538,000
California	\$54,191,000	\$542,000	\$53,649,000	North Dakota	\$3,720,000	\$37,000	\$3,683,000
Colorado	\$6,061,000	\$61,000	\$6,000,000	Ohio	\$42,656,000	\$427,000	\$42,229,000
Connecticut	\$9,282,000	\$93,000	\$9,189,000	Oklahoma	\$6,122,000	\$61,000	\$6,061,000
Delaware	\$3,720,000	\$37,000	\$3,683,000	Oregon	\$8,559,000	\$86,000	\$8,473,000
Florida	\$25,576,000	\$256,000	\$25,320,000	Pennsylvania	\$30,014,000	\$300,000	\$29,714,000
Georgia	\$12,811,000	\$128,000	\$12,683,000	Puerto Rico	\$9,883,000	\$99,000	\$9,784,000
Hawaii	\$5,868,000	\$59,000	\$5,809,000	Rhode Island	\$5,088,000	\$51,000	\$5,037,000
Idaho	\$3,720,000	\$37,000	\$3,683,000	South Carolina	\$7,762,000	\$78,000	\$7,684,000
Illinois	\$34,269,000	\$343,000	\$33,926,000	South Dakota	\$3,720,000	\$37,000	\$3,683,000
Indiana	\$18,261,000	\$183,000	\$18,078,000	Tennessee	\$11,007,000	\$110,000	\$10,897,000
Iowa	\$10,255,000	\$103,000	\$10,152,000	Texas	\$34,632,000	\$346,000	\$34,286,000
Kansas	\$6,839,000	\$68,000	\$6,771,000	Utah	\$3,992,000	\$40,000	\$3,952,000
Kentucky	\$9,644,000	\$96,000	\$9,548,000	Vermont	\$3,720,000	\$37,000	\$3,683,000
Louisiana	\$8,329,000	\$83,000	\$8,246,000	Virginia	\$15,507,000	\$155,000	\$15,352,000
Maine	\$5,865,000	\$59,000	\$5,806,000	Washington	\$13,177,000	\$132,000	\$13,045,000
Maryland	\$18,326,000	\$183,000	\$18,143,000	West Virginia	\$11,812,000	\$118,000	\$11,694,000
Massachusetts	\$25,726,000	\$257,000	\$25,469,000	Wisconsin	\$20,484,000	\$205,000	\$20,279,000
Michigan	\$32,580,000	\$326,000	\$32,254,000	Wyoming	\$3,720,000	\$37,000	\$3,683,000
Minnesota	\$13,927,000	\$139,000	\$13,788,000				
Mississippi	\$6,827,000	\$68,000	\$6,759,000				
Missouri	\$21,005,000	\$210,000	\$20,795,000	District of Columbia	\$3,720,000	\$37,000	\$3,683,000
Montana	\$3,720,000	\$37,000	\$3,683,000	American Samoa***	\$4,119,000	\$41,000	\$4,078,000
Nebraska	\$3,876,000	\$39,000	\$3,837,000	Guam***	\$2,980,000	\$30,000	\$2,950,000
Nevada	\$3,720,000	\$37,000	\$3,683,000	Northern Marianas***	\$1,914,000	\$40,000	\$1,874,000
New Hampshire	\$7,572,000	\$76,000	\$7,496,000	Virgin Islands***	\$2,390,000	\$25,000	\$2,365,000
Total Funds Available to States					\$ 757,737,000		
<u>National Set-Asides</u>							
Tribal Set-Aside ****					\$15,515,000		
Clean Watersheds Needs Survey*****					\$1,500,000		
National American Iron & Steel Administrative Set-Aside					\$1,000,358		
Total SRF Appropriation					\$ 775,752,358		
* Based on Appropriation of \$1,638,861,000 less \$863,108,642 for Congressional Directed Spending Projects.							
** Section 604(b) of the CWA sets the annual minimum amount for 604(b) grants at \$100,000. These amounts include the additional funds needed to meet this statutory floor when the sum of 1% of all CWSRF Bipartisan Infrastructure Law (BIL) and Base allotments is less than \$100,000.							
*** The FY 2023 appropriation allows EPA to reserve up to 1.5% of the funds appropriated less any amounts reserved for the Indian tribal set-aside for direct grants to American Samoa, Guam, Northern Marianas, and the Virgin Islands.							
**** The FY 2023 appropriation allows EPA to reserve an annual amount equal to 2% of all funds appropriated (i.e, BIL and base) or \$30M, whichever is greater, for direct grants to Indian tribes. This amount only reflects the FY 2023 base portion of the annual total reserved for Indian tribes.							
***** The FY 2023 appropriation allows EPA to reserve up to \$1.5M to conduct the Clean Watershed Needs Survey.							

FY 2023**Distribution of Clean Water SRF Appropriation****2023 Consolidated Appropriations Additional Subsidization and Green Project Reserve (GPR) Amounts**

State	Capitalization Grant	Required Additional Subsidy (10%)*	Required GPR (10%)	State	Capitalization Grant	Required Additional Subsidy (10%)*	Required GPR (10%)
Alabama	\$8,388,000	\$838,800	\$838,800	New Jersey	\$30,653,000	\$3,065,300	\$3,065,300
Alaska	\$4,490,000	\$449,000	\$449,000	New Mexico	\$3,683,000	\$368,300	\$368,300
Arizona	\$5,067,000	\$506,700	\$506,700	New York	\$82,792,000	\$8,279,200	\$8,279,200
Arkansas	\$4,907,000	\$490,700	\$490,700	North Carolina	\$13,538,000	\$1,353,800	\$1,353,800
California	\$53,649,000	\$5,364,900	\$5,364,900	North Dakota	\$3,683,000	\$368,300	\$368,300
Colorado	\$6,000,000	\$600,000	\$600,000	Ohio	\$42,229,000	\$4,222,900	\$4,222,900
Connecticut	\$9,189,000	\$918,900	\$918,900	Oklahoma	\$6,061,000	\$606,100	\$606,100
Delaware	\$3,683,000	\$368,300	\$368,300	Oregon	\$8,473,000	\$847,300	\$847,300
Florida	\$25,320,000	\$2,532,000	\$2,532,000	Pennsylvania	\$29,714,000	\$2,971,400	\$2,971,400
Georgia	\$12,683,000	\$1,268,300	\$1,268,300	Puerto Rico	\$9,784,000	\$978,400	\$978,400
Hawaii	\$5,809,000	\$580,900	\$580,900	Rhode Island	\$5,037,000	\$503,700	\$503,700
Idaho	\$3,683,000	\$368,300	\$368,300	South Carolina	\$7,684,000	\$768,400	\$768,400
Illinois	\$33,926,000	\$3,392,600	\$3,392,600	South Dakota	\$3,683,000	\$368,300	\$368,300
Indiana	\$18,078,000	\$1,807,800	\$1,807,800	Tennessee	\$10,897,000	\$1,089,700	\$1,089,700
Iowa	\$10,152,000	\$1,015,200	\$1,015,200	Texas	\$34,286,000	\$3,428,600	\$3,428,600
Kansas	\$6,771,000	\$677,100	\$677,100	Utah	\$3,952,000	\$395,200	\$395,200
Kentucky	\$9,548,000	\$954,800	\$954,800	Vermont	\$3,683,000	\$368,300	\$368,300
Louisiana	\$8,246,000	\$824,600	\$824,600	Virginia	\$15,352,000	\$1,535,200	\$1,535,200
Maine	\$5,806,000	\$580,600	\$580,600	Washington	\$13,045,000	\$1,304,500	\$1,304,500
Maryland	\$18,143,000	\$1,814,300	\$1,814,300	West Virginia	\$11,694,000	\$1,169,400	\$1,169,400
Massachusetts	\$25,469,000	\$2,546,900	\$2,546,900	Wisconsin	\$20,279,000	\$2,027,900	\$2,027,900
Michigan	\$32,254,000	\$3,225,400	\$3,225,400	Wyoming	\$3,683,000	\$368,300	\$368,300
Minnesota	\$13,788,000	\$1,378,800	\$1,378,800				
Mississippi	\$6,759,000	\$675,900	\$675,900				
Missouri	\$20,795,000	\$2,079,500	\$2,079,500				
Montana	\$3,683,000	\$368,300	\$368,300				
Nebraska	\$3,837,000	\$383,700	\$383,700				
Nevada	\$3,683,000	\$368,300	\$368,300				
New Hampshire	\$7,496,000	\$749,600	\$749,600				

* Eligible Recipients: Any CWSRF-Eligible Borrower

FY 2023
Distribution of Clean Water SRF Appropriation
2023 Clean Water Act (CWA) Statutory Additional Subsidization Amounts

State	Capitalization Grant	Required Minimum (10%)*	Required Maximum (30%)*	State	Capitalization Grant	Required Minimum (10%)*	Required Maximum (30%)*
Alabama	\$8,388,000	\$838,800	\$2,516,400	New Jersey	\$30,653,000	\$3,065,300	\$9,195,900
Alaska	\$4,490,000	\$449,000	\$1,347,000	New Mexico	\$3,683,000	\$368,300	\$1,104,900
Arizona	\$5,067,000	\$506,700	\$1,520,100	New York	\$82,792,000	\$8,279,200	\$24,837,600
Arkansas	\$4,907,000	\$490,700	\$1,472,100	North Carolina	\$13,538,000	\$1,353,800	\$4,061,400
California	\$53,649,000	\$5,364,900	\$16,094,700	North Dakota	\$3,683,000	\$368,300	\$1,104,900
Colorado	\$6,000,000	\$600,000	\$1,800,000	Ohio	\$42,229,000	\$4,222,900	\$12,668,700
Connecticut	\$9,189,000	\$918,900	\$2,756,700	Oklahoma	\$6,061,000	\$606,100	\$1,818,300
Delaware	\$3,683,000	\$368,300	\$1,104,900	Oregon	\$8,473,000	\$847,300	\$2,541,900
Florida	\$25,320,000	\$2,532,000	\$7,596,000	Pennsylvania	\$29,714,000	\$2,971,400	\$8,914,200
Georgia	\$12,683,000	\$1,268,300	\$3,804,900	Puerto Rico	\$9,784,000	\$978,400	\$2,935,200
Hawaii	\$5,809,000	\$580,900	\$1,742,700	Rhode Island	\$5,037,000	\$503,700	\$1,511,100
Idaho	\$3,683,000	\$368,300	\$1,104,900	South Carolina	\$7,684,000	\$768,400	\$2,305,200
Illinois	\$33,926,000	\$3,392,600	\$10,177,800	South Dakota	\$3,683,000	\$368,300	\$1,104,900
Indiana	\$18,078,000	\$1,807,800	\$5,423,400	Tennessee	\$10,897,000	\$1,089,700	\$3,269,100
Iowa	\$10,152,000	\$1,015,200	\$3,045,600	Texas	\$34,286,000	\$3,428,600	\$10,285,800
Kansas	\$6,771,000	\$677,100	\$2,031,300	Utah	\$3,952,000	\$395,200	\$1,185,600
Kentucky	\$9,548,000	\$954,800	\$2,864,400	Vermont	\$3,683,000	\$368,300	\$1,104,900
Louisiana	\$8,246,000	\$824,600	\$2,473,800	Virginia	\$15,352,000	\$1,535,200	\$4,605,600
Maine	\$5,806,000	\$580,600	\$1,741,800	Washington	\$13,045,000	\$1,304,500	\$3,913,500
Maryland	\$18,143,000	\$1,814,300	\$5,442,900	West Virginia	\$11,694,000	\$1,169,400	\$3,508,200
Massachusetts	\$25,469,000	\$2,546,900	\$7,640,700	Wisconsin	\$20,279,000	\$2,027,900	\$6,083,700
Michigan	\$32,254,000	\$3,225,400	\$9,676,200	Wyoming	\$3,683,000	\$368,300	\$1,104,900
Minnesota	\$13,788,000	\$1,378,800	\$4,136,400				
Mississippi	\$6,759,000	\$675,900	\$2,027,700				
Missouri	\$20,795,000	\$2,079,500	\$6,238,500				
Montana	\$3,683,000	\$368,300	\$1,104,900				
Nebraska	\$3,837,000	\$383,700	\$1,151,100				
Nevada	\$3,683,000	\$368,300	\$1,104,900				
New Hampshire	\$7,496,000	\$749,600	\$2,248,800				

* Eligible Recipients: See 33 USC 1383(j)(1)

FY 2023
Distribution of Clean Water SRF Appropriation
2023 Clean Water Act (CWA) 604(b) Grants to States and Territories (BIL and Base)

State	604(b) Grant			State	604(b) Grant		
	BIL Total*	Base**	FY 2023 Total		BIL Total*	Base**	FY 2023 Total
Alabama	\$259,000	\$85,000	\$344,000	New Jersey	\$948,000	\$310,000	\$1,258,000
Alaska	\$139,000	\$45,000	\$184,000	New Mexico	\$114,000	\$37,000	\$151,000
Arizona	\$157,000	\$51,000	\$208,000	New York	\$2,561,000	\$836,000	\$3,397,000
Arkansas	\$152,000	\$50,000	\$202,000	North Carolina	\$419,000	\$137,000	\$556,000
California	\$1,660,000	\$542,000	\$2,202,000	North Dakota	\$114,000	\$37,000	\$151,000
Colorado	\$185,000	\$61,000	\$246,000	Ohio	\$1,306,000	\$427,000	\$1,733,000
Connecticut	\$284,000	\$93,000	\$377,000	Oklahoma	\$187,000	\$61,000	\$248,000
Delaware	\$114,000	\$37,000	\$151,000	Oregon	\$262,000	\$86,000	\$348,000
Florida	\$784,000	\$256,000	\$1,040,000	Pennsylvania	\$919,000	\$300,000	\$1,219,000
Georgia	\$392,000	\$128,000	\$520,000	Puerto Rico	\$303,000	\$99,000	\$402,000
Hawaii	\$180,000	\$59,000	\$239,000	Rhode Island	\$155,000	\$51,000	\$206,000
Idaho	\$114,000	\$37,000	\$151,000	South Carolina	\$238,000	\$78,000	\$316,000
Illinois	\$1,049,000	\$343,000	\$1,392,000	South Dakota	\$114,000	\$37,000	\$151,000
Indiana	\$559,000	\$183,000	\$742,000	Tennessee	\$337,000	\$110,000	\$447,000
Iowa	\$314,000	\$103,000	\$417,000	Texas	\$1,060,000	\$346,000	\$1,406,000
Kansas	\$209,000	\$68,000	\$277,000	Utah	\$122,000	\$40,000	\$162,000
Kentucky	\$295,000	\$96,000	\$391,000	Vermont	\$114,000	\$37,000	\$151,000
Louisiana	\$255,000	\$83,000	\$338,000	Virginia	\$475,000	\$155,000	\$630,000
Maine	\$180,000	\$59,000	\$239,000	Washington	\$403,000	\$132,000	\$535,000
Maryland	\$561,000	\$183,000	\$744,000	West Virginia	\$361,000	\$118,000	\$479,000
Massachusetts	\$788,000	\$257,000	\$1,045,000	Wisconsin	\$627,000	\$205,000	\$832,000
Michigan	\$997,000	\$326,000	\$1,323,000	Wyoming	\$114,000	\$37,000	\$151,000
Minnesota	\$426,000	\$139,000	\$565,000				
Mississippi	\$209,000	\$68,000	\$277,000				
Missouri	\$644,000	\$210,000	\$854,000	District of Columbia	\$114,000	\$37,000	\$151,000
Montana	\$114,000	\$37,000	\$151,000	American Samoa	\$129,000	\$41,000	\$170,000
Nebraska	\$119,000	\$39,000	\$158,000	Guam	\$94,000	\$30,000	\$124,000
Nevada	\$114,000	\$37,000	\$151,000	Northern Marianas	\$60,000	\$40,000	\$100,000
New Hampshire	\$231,000	\$76,000	\$307,000	Virgin Islands	\$75,000	\$25,000	\$100,000

*Bipartisan Infrastructure Law (BIL) Total includes General Supplemental and Emerging Contaminants funding.

**Section 604(b) of the CWA sets the annual minimum amount for 604(b) grants at \$100,000. These amounts include the additional funds needed to meet this statutory floor when the sum of 1% of all CWSRF BIL and Base allotments is less than \$100,000.

Search EPA.gov

Building the Capacity of Drinking Water Systems

CONTACT US <<https://epa.gov/dwcapacity/forms/contact-us-about-building-capacity-drinking-water-systems>>

Emerging Contaminants (EC) in Small or Disadvantaged Communities Grant (SDC)

The *Emerging Contaminants in Small or Disadvantaged Communities grant program* will provide states and territories with grants to public water systems in small or disadvantaged communities to address emerging contaminants, including PFAS. Grants will be awarded non-competitively to states and territories.

- Press Release
- Background
- Funding Allotments
- Eligible Applicants
- Eligible Projects
- Implementation
- Timeline
- Outreach
- Build America, Buy America (BABA) Act
- Contacts

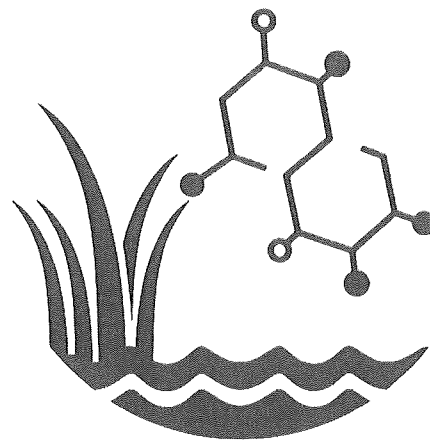

Biden-Harris Administration Announces \$2 Billion in Bipartisan Infrastructure Law Funding to States and Territories to Address Emerging Contaminants like PFAS in Drinking Water

On February 13, 2023, the U.S. Environmental Protection Agency (EPA) Administrator Michael S. Regan announced the availability of \$2 billion from President Biden's Bipartisan Infrastructure Law (BIL) to address emerging contaminants, like Per- and Polyfluoroalkyl Substances (PFAS) in drinking water across the country. This investment, which is allocated to states and territories, will be made available to communities as grants through EPA's Emerging Contaminants in Small or Disadvantaged Communities (EC-SDC) Grant Program and will promote access to safe and clean water in small, rural, and disadvantaged communities while supporting local economies. Administrator Regan announced the water infrastructure investments in Maysville, North Carolina while holding a community roundtable with North Carolina Department of Environmental Quality Secretary Elizabeth S. Biser and other state and local leaders.

EPA is also releasing the Emerging Contaminants in Small or Disadvantaged Communities Grant Implementation document. The implementation document provides states and communities with the information necessary to use this funding to address local water quality and public health challenges. These grants will enable communities to improve local water infrastructure and reduce emerging contaminants in drinking water by implementing solutions such as installing necessary treatment solutions.

Background

This grant focuses on projects in which the primary purpose is to address the challenges of PFAS in drinking water, whether it is found in the public water system or in source water. Projects that address any contaminant listed in any of EPA's Contaminant Candidate Lists <<https://epa.gov/ccl>> are also eligible. To continue the use of the funds to maximize public health protection, EPA also encourages states to address perchlorate and contaminants that have higher levels of health concerns in small and disadvantaged communities. BIL provides \$50 billion to EPA's water programs. Of that amount, \$5 billion is appropriated to the EC-SDC grant program. In spring of 2022, the

agency announced a Letter of Intent (LOI) whereby states and territories seeking grant funding were to submit LOI correspondence to EPA. EPA used this information to allocate funds according to a formula and administer the grant accordingly.

The EC-SDC grant program's annual appropriation is \$1 billion for each fiscal year from FY2022-2026. There is no cost-share/match applicable for the funding made available under this grant program.

Funding Allotments

EPA awards funding to states based on an allocation formula that includes factors such as population, number of water systems, and data related to emerging contaminants.

View the  FY22-23 EC Allotment Memo (pdf) <https://epa.gov/system/files/documents/2023-02/fy22_fy23_combined_bil_ec_allotments%20memo%20to%20wdds_february%202023_signed.pdf> (307.02 KB)

Eligible Applicants

Established as a noncompetitive grant program, eligibility to apply for and receive funds is limited to the fifty states and Puerto Rico, Guam, the U.S. Virgin Islands, American Samoa and the Commonwealth of the Northern Mariana Islands.

States are to use this funding to make grants to eligible emerging contaminant projects and/or activities in small or disadvantaged communities. The target beneficiaries are the eligible recipients for this grant, communities as described in section 1459A of the Safe Drinking Water Act (SDWA):

- **“Disadvantaged Community”** is one determined by the state to be disadvantaged under the affordability criteria established by the state under section 1452(d)(3) of the Safe Drinking Water Act or may become a disadvantaged community as a result of carrying out a project or activity under the grant program. As with the Drinking Water State Revolving Fund program, each state has statutory discretion to set its own criteria.

- **“Small Community”** is one that has a population of less than 10,000 individuals that the Administrator determines does not have the capacity to incur debt sufficient to finance a project or activity under the grant program. This is a statutory definition.

EPA will distribute the national tribal allotment of 2% of the appropriations, estimated at \$20M in FY22 funding, through the Grant Program as an allocation to regions based upon the Drinking Water Infrastructure Grants Tribal Set Aside Program (DWIG-TSA) allocation formula. Regional offices will develop the procedures and schedule for annual selection of projects and activities, obligation of funds, or distribution of grants.

Eligible Projects

States and territories will be able to apply for funding through the *Emerging Contaminants in Small or Disadvantaged Communities* grant program later this year.

Eligible activities include:

- Efforts to address emerging contaminants in drinking water that would benefit a small or disadvantaged community on a per household basis;
- Technical assistance to evaluate emerging contaminant problems;
- Programs to provide household water-quality testing, including testing for unregulated contaminants;
- Local contractor training;
- Activities necessary and appropriate for a state to respond to an emerging contaminant.

Implementation

In addition to the release of the first allotment memo, EPA is releasing the implementation document for participating states and territories to use as guidance through the development and application submission for the grant. States and territories will collaborate with the EPA regional offices on draft projects and workplans for approval prior to applying for grant funding in Grants.gov [🔗](https://www.grants.gov/)

[<https://www.grants.gov/>](https://www.grants.gov/) and receiving awards. EPA will continue to provide additional

resources to states and territories as the grant program moves forward in implementation, including communication on technical assistance and other topics relating to emerging contaminants.

When reviewing the draft workplans, EPA Regions must be able to determine that activities conform to all applicable requirements of the grant. Participating states must submit their final application package to the Grants.gov [🔗](https://www.grants.gov/) website. Participating states are encouraged to submit applications as soon as possible. Funding is anticipated to begin awarded to the states and territories as early as FY23. EPA Regional offices are the primary points of contact to approve grant applications and award funding.

Annually, the grant program will provide additional information or revise the document as necessary to continue providing efficient and transparent information pertaining to the implementation of the grant program.

Click here to view the  Implementation Manual (pdf)

https://epa.gov/system/files/documents/2023-02/ec%20grant%20implementation%20manual_february%202023_final_508_0.pdf (615.86 KB)

Click here to view Frequently Asked Questions about the EC-SDC Grant Program

<https://epa.gov/dwcapacity/frequently-asked-questions-about-emerging-contaminants-small-or-disadvantaged>

Timeline

An updated timeline is not yet available for the FY 2023 grant cycle and application process. A general overview of the application process is outlined below. All awarded projects are expected to have a project period of four years.

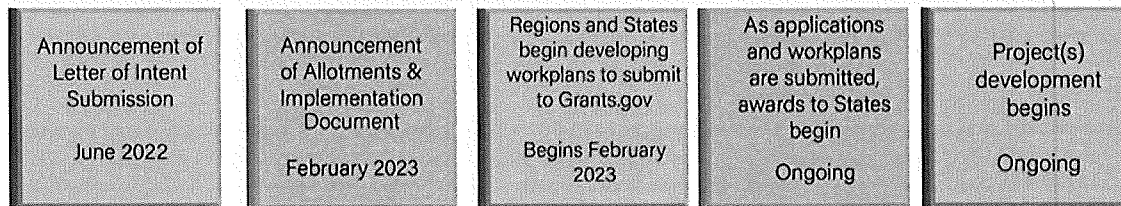

Outreach

To learn more about the grant program, the following resources are available.

 Emerging Contaminants SDC Factsheet (pdf) <https://epa.gov/system/files/documents/2023-03/ec%20sdc%20factsheet_03142023.pdf> (460.22 KB, March 14, 2023)

 BIL EC Funding Sources Comparison Factsheet (pdf) <<https://epa.gov/system/files/documents/2023-03/bil%20ec%20funding%20sources%20comparison%20factsheet.pdf>> (213.98 KB, March 13, 2023)

Build America, Buy America (BABA) Act

Overview

The Infrastructure Investment and Jobs Act ("IIJA") includes the Build America, Buy America Act ("the Act"). The Act strengthens Made in America Laws and will bolster America's industrial base, protect national security, and support high-paying jobs. The Act requires that no later than May 14, 2022, the head of each covered Federal agency shall ensure that "none of the funds made available for a Federal financial assistance program for infrastructure, including each deficient program, may be obligated for a project unless all of the **iron, steel, manufactured products, and construction materials** used in the project are produced in the United States."

The Office of Management and Budget's (OMB) Made in America Office released its guidance for implementing the Build America, Buy America Act [↗](#). In regards to grant funding, OMB is proposing to revise the current OMB Guidance for Grants and

Agreements [↗](#). The proposed amendments are intended to provide guidance and clarify requirements for the manufactured products content test and non-ferrous construction materials. Public comments were due March 13, 2023.

Webinar presentations

- Build America, Buy America Act Implementation Webinar Presentation (April 2022) (pdf) <https://epa.gov/system/files/documents/2022-05/ow_babaimplementationwebinarpresentation-apr2022.pdf> (1.35 MB)
- Build America, Buy America Act Office of Water Implementation Procedures Webinar (November 2022) (pdf) <<https://epa.gov/system/files/documents/2022-11/baba%20ow%20implementation%20procedures%20webinar.pdf>> (3.61 MB)

The Drinking Water Grants Program team is working to standardize and implement the process to support grant recipients with the BABA requirements and how to request/apply for a waiver if they are eligible. In that effort, we have established a grant inbox for the purpose of questions and eventually receiving waiver requests. Please do not hesitate to reach out to the grants team points of contact at HQ or send your questions/requests to BABA-DrinkingWaterGrants@epa.gov

Contact Information

Click here for Regional and State contacts: **Regional and State Contacts**

<<https://epa.gov/dwcapacity/contacts-emerging-contaminants-ec-small-or-disadvantaged-communities-grant-sdc>>

Agency Contact: Yvonne Gonzalez, gonzalez.yvonne@epa.gov

Grant Contact: Lida Daly, daly.lida@epa.gov

For questions or more information on any of the WIIN grants,
please contact WIINDrinkingWaterGrants@epa.gov

Return to main grants page <<https://epa.gov/ground-water-and-drinking-water/drinking-water-grants>>

[Building the Capacity of Drinking Water Systems Home <https://epa.gov/dwcapacity>](https://epa.gov/dwcapacity)

[About Capacity Development <https://epa.gov/dwcapacity/learn-about-capacity-development>](https://epa.gov/dwcapacity/learn-about-capacity-development)

[About Operator Certification <https://epa.gov/dwcapacity/about-operator-certification>](https://epa.gov/dwcapacity/about-operator-certification)

[About Water System Partnerships <https://epa.gov/dwcapacity/learn-about-water-system-partnerships>](https://epa.gov/dwcapacity/learn-about-water-system-partnerships)

[About Asset Management <https://epa.gov/dwcapacity/about-asset-management>](https://epa.gov/dwcapacity/about-asset-management)

[Contact Us <https://epa.gov/dwcapacity/forms/contact-us-about-building-capacity-drinking-water-systems>](https://epa.gov/dwcapacity/forms/contact-us-about-building-capacity-drinking-water-systems)
to ask a question, provide feedback, or report a problem.

LAST UPDATED ON MAY 1, 2023



Discover.

Accessibility Statement <<https://epa.gov/accessibility/epa-accessibility-statement>>

Budget & Performance <<https://epa.gov/planandbudget>>

Contracting <<https://epa.gov/contracts>>

EPA www Web Snapshot <<https://epa.gov/utilities/wwwepagov-snapshots>>

Grants <<https://epa.gov/grants>>

No FEAR Act Data <<https://epa.gov/ocr/whistleblower-protections-epa-and-how-they-relate-non-disclosure-agreements-signed-epa>>

Plain Writing <<https://epa.gov/web-policies-and-procedures/plain-writing>>

Privacy <<https://epa.gov/privacy>>

Privacy and Security Notice <<https://epa.gov/privacy/privacy-and-security-notice>>

Connect.

Data.gov  <<https://www.data.gov/>>

Inspector General <<https://epa.gov/office-inspector-general/about-epas-office-inspector-general>>

Jobs <<https://epa.gov/careers>>

Newsroom <<https://epa.gov/newsroom>>

Open Government <<https://epa.gov/data>>

Regulations.gov  <<https://www.regulations.gov/>>

Subscribe <<https://epa.gov/newsroom/email-subscriptions-epa-news-releases>>

USA.gov  <<https://www.usa.gov/>>

White House  <<https://www.whitehouse.gov/>>

Ask.

Contact EPA <<https://epa.gov/home/forms/contact-epa>>

EPA Disclaimers <<https://epa.gov/web-policies-and-procedures/epa-disclaimers>>

Hotlines <<https://epa.gov/aboutepa/epa-hotlines>>

FOIA Requests <<https://epa.gov/foia>>

Frequent Questions <<https://epa.gov/home/frequent-questions-specific-epa-programsttopics>>

Follow.



12 I.

Pioneer Bank & Trust *Local.*

Date 4/28/23 Page 4
Primary Account Ending 6395

CERTIFICATE OF DEPOSIT				
Account Number	Current Balance	Interest Rate	Maturity Date	2023 Interest
Ending 3571	500,863.01	0.7500%	6/11/23	863.01

Account information

Owner	Town Of Hermosa
Next payment date	6/11/2023
Original balance	\$500,000.00
Issue date	12/13/2022
CD Term	90 Days

Activity

Last payment date	3/13/2023
Last deposit date	12/13/2022
Maturity date	6/11/2023
Last renewal	3/13/2023

Interest

Rate	0.75%
Term	90 Days
Accrued	\$607.21
Paid YTD	\$863.01
Paid last year	\$0.00

**Hermosa Connects Inc
Meeting Minutes
April 11, 2023 @ 0830
Hermosa Coffee House**



Meeting called to order @ 0832 by Valena Baker.

Attendees & Introductions: Dan Martin, Valena Baker, Leo Van Sambeek, Michelle Fischer, Vicki Henrichsen, Karry Sears, Crystal Strand, Auralee Jobgen, Shanna Harris-Clarke, Joan Harris, Bob Knapp, Cathy Mack, Linda Hasselstrom, Peg Ryan, Sarah Gadbois, Ali VanSambeek, Monika Serviss, Dennis McMillin, Nick Brengle & Cathy Dahl.

Officer's Reports

President/Vice President Report

Rick Mills absent at this time, out of town. Dan Martin would like to turn the meeting over to Valena Baker.

Secretary's Report

Minutes of March 14, 2023 Meeting was presented by Valena Baker. No corrections were needed. Leo VanSambeek made a motion to approve, second by Michelle Fischer.

Treasurer's Report

Month of March organizational account details were presented by Valena Baker.

Dan Martin made a motion to approve, second by Joan Harris.

Valena Baker needed input as to the reimbursement for the expenses that Leo Van Sambeek incurred for Hermosa Connects to get officially licensed with the state and other supplemental costs. Leo Van Sambeek stated to the group that his costs were donated to Hermosa Connects. He is not expecting reimbursement. He was thanked by attendees.

Valena Baker explained the research that Paypal was ideal with nonprofit and that Venmo did not have the nonprofit platform yet, the organization will use Paypal to receive funds for events at this time. Valena Baker and Ali Van Sambeek worked together to bring the platform forward for the Farmers Market/Vendor Fair event.

Valena Baker brought up the Town of Hermosa BBB,1% Tax topic. Valena read the municipal statute 31.14 'Use of Revenue' to the group. Peg Ryan had ideas and input on use of these funds to benefit the community. The group was receptive to the ideas that Peg Ryan introduced. Valena Baker asked the group if the funds were of interest to the group to be on file, present a copy or include in emails with the other information for the meetings. The group made it apparent in responses that it should be included in the emails with the other meeting details. Monika Serviss was present for the group response and agreed to provide this information to be included.

Hermosa Connects Inc
Meeting Minutes
April 11, 2023 @ 0830
Hermosa Coffee House

Old Business

Farmer's Market & Vendor Fair Committee Report

The committee explained the current status of the planned Farmer's Market and Vendor Event on June 24th. Joan Harris made a request to combine advertising. Further discussions included displays, banners, & tables. At this time 12 have signed up to participate. The cost is \$20.00 per table.

Website/Marketing Committee

Ali Van Sambeek presented for the Website/Marketing Committee. The website is now live. There are multiple aspects that are included on the site at this time. There is more to come. Suggestion was made to include VRBO's & AIR BNB's. Ali Van Sambeek explained using social media effectively, to the group, in regards to visibility and activity.

The Hermosa Bank Building

Linda Hasselstrom discussed the building in Hermosa known as "The Bank". She is in the process of a historical designation of the building. She shared the status of this project with the group.

The Park, North 3rd Street (Agenda didn't reflect this topic. Oversight of Secretary)

Joan Harris presented information she gathered on the 3rd St. designated parcel of land to be used as a park. It was shared she attended a meeting with a group that could potentially provide a grant. The deadline had passed. The group, and Sarah Gadbois, had further discussion of the other options that may still be usable for the project.

New Business

QRS Code Applications

Valena Baker presented the map she created for her coffee house and that it included a QRS code at the location. The idea was that this was something that could be used as an interactive tool. That a map that included 57744 area businesses might be a project to consider and represented by QRS codes for all businesses.

Hermosa Organizational Entities (IRS and State)

Valena Baker shared two compiled listings to share with the group. One was an IRS listing of 'Tax Exempt Organizations' by search of Hermosa, South Dakota. The other listing of South Dakota State Businesses by Name Search: Hermosa. It was asked to have the group look over the list and determine if they knew who some of these groups were and also were there groups that were doing similar activities in Hermosa. The listings were presented primarily for informational purposes.

Hermosa Connects Inc
Meeting Minutes
April 11, 2023 @ 0830
Hermosa Coffee House

Open Group Discussions/Presentations

Leo Van Sambeek

Serving on the Board of Directors of the Custer County Library as well as a committee that focuses on a branch library to replace the current one. To see a Custer County Courthouse affiliated building that could serve many functions including the Hermosa area library. The location proposed would be between the softball fields and Ferguson development near the fairgrounds in Hermosa.

Leo Van Sambeek

A High School Rodeo event is coming to Hermosa. The idea is proposed to have Hermosa Connects donate food or be a lunch sponsor for the one (1) hour break during this event. Date to be determined.

Leo Van Sambeek

Reported to the group that he is closer to having the 501(c)3 completed. It was asked of the group to have some extra 'eyes' on the documents. Linda Hasselstrom, Shanna Harris and Crystal Strand offered to proofread.

Valena Baker

An idea is proposed to do a 'Spotlight' of local businesses with a Q & A opportunity. Separate meeting?

Peg Ryan

Proposed multiple ideas and topics to consider: Chamber of Commerce-Custer, Non-Profit Rates, Weekly Newsletter-Advertising & getting affiliated with other Chambers.

Meeting Adjournment at 0945. Motion Dan Martin, Second by Linda Hasselstrom.

Valena Baker

Secretary/Treasurer

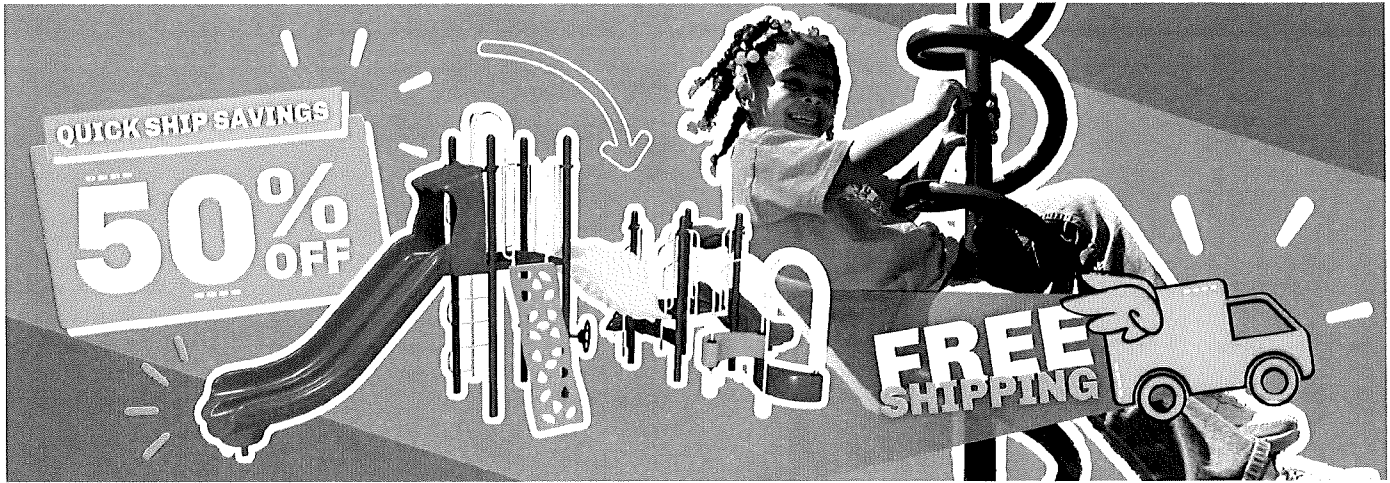

Little Dipper

Sale Price: \$11,058
-MSRP: \$22,117



Ages: 2 to 5 Use Zone: 22' x 26'
Capacity: 15-20 Fall Height: 2'8"

Also in Carnival



Play Parade

Sale Price: \$13,948
MSRP: \$27,895

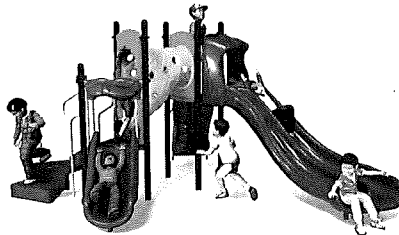

Ages: 2 to 12 Use Zone: 26' x 31'
Capacity: 15-20 Fall Height: 56"

Also in Springtime



Seas the Day

Sale Price: \$15,794
MSRP: \$31,587

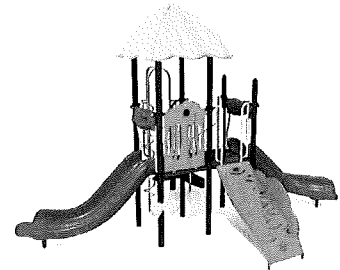

Ages: 2 to 12 Use Zone: 26'11" x 31'10"
Capacity: 25-30 Fall Height: 48"

Also in Springtime

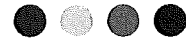

Showtime

Sale Price: \$17,649
MSRP: \$35,297

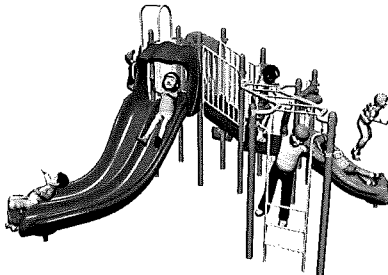

Ages: 5 to 12 Use Zone: 27'8" X 29'7"
Capacity: 25-30 Fall Height: 77"

Also in Springtime



Treasure Hunt

Sale Price: \$22,731
MSRP: \$45,463

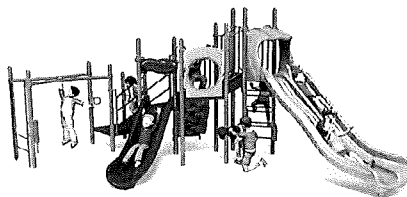

Ages: 5 to 12 Use Zone: 27' x 39'
Capacity: 30-35 Fall Height: 72"

Also in Candy Shop



Cabana Bay

Sale Price: \$26,580
MSRP: \$53,160

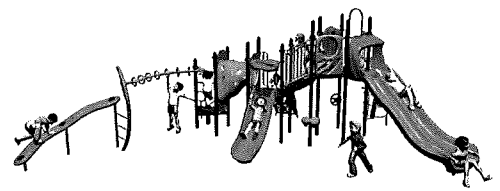

Ages: 5 to 12 Use Zone: 36' x 45'
Capacity: 35-40 Fall Height: 75"

Also in Springtime



CALL YOUR SALES REP TODAY: 855-973-1173

OR REGISTER NOW FOR 50% OFF + FREE SHIPPING → WWW.BYOPLAYGROUND.COM/CREATEPLAY

2023 SWING STYLES, PRICES, USE ZONE, COLOR CHOICES

Standard Commercial Swing Set, Galvanized

- 1 Bay (2 Seats) \$1,986 (32'x25')
- 2 Bay (4 Seats) \$2,879 (32'x36')
- 3 Bay (6 Seats) \$4,098 (32'x47')
- 4 Bay (8 Seats) \$5,319 (32'x58')

Seat colors: red,green,blue,yellow,black,tan

Frame Fitting color: Choices below

Metal:

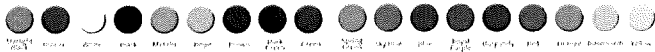

P&P 8' High Single Post Swing (5" posts)

- 1 Bay (2 Seats) \$2,342 (32'x24')
- 2 Bay (4 Seats) \$3,994 (32'x36')

Seat Colors: red,green,blue,yellow,black,tan

Post Color: Choices below

Metal:

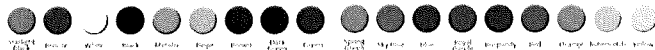

Arch Swing Set 3 1/2" Top Rail and Legs

Also available with 5" top rail

- 1 Bay (2 Seats) \$2,582 (32x25')
- 2 Bay (4 Seats) \$4,305 (32'x38')
- 3 Bay (6 Seats) \$6,029 (32'x50')
- 4 Bay (8 Seats) \$7,752 (32'x62')

Seat colors: red,green,blue,yellow,black,tan

Frame Fitting color: Choices below

Metal:

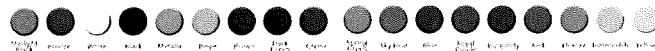

8' Toddler T-Swing

- 1 Bay (2 Seats) \$2,459 (23'x25')

Toddler Seat Colors: red,green,blue,yellow,black

Coated Chains available add'l charge: blue,green,yellow

Frame Fitting color: choices below

Metal:

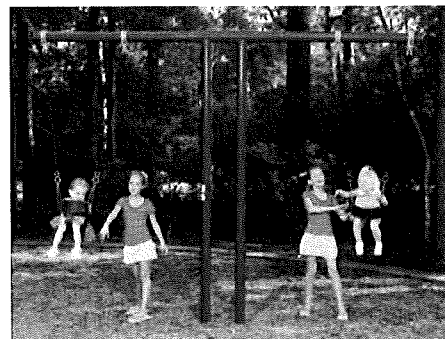
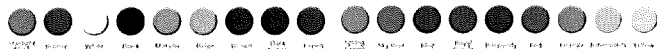

2023 SWING STYLES, PRICES, USE ZONE, COLOR CHOICES

8' Single Post Swing with Shade (5" posts)

1 Bay (2 Seats) \$10,888 (32'x34')

2 Bay (4 Seats) \$15,951 (32'x36')

Seat Colors: red,green,blue,yellow,black,tan

Post Color: choices below

Metal:

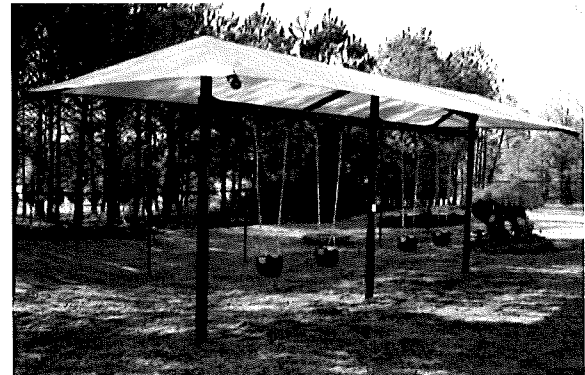

Arch Tire Swing Set (5" posts)

1 Bay (1 Tire) \$4,054 (27'x21')

2 Bay (2 Tires) \$6,880 (42'x21')

3 Bay (3 Tires) \$9,706 (56'x21')

4 Bay (4 Tires) \$12,533 (71'x21')

Post Colors: choices below

Color Options:

Posts and Metals:

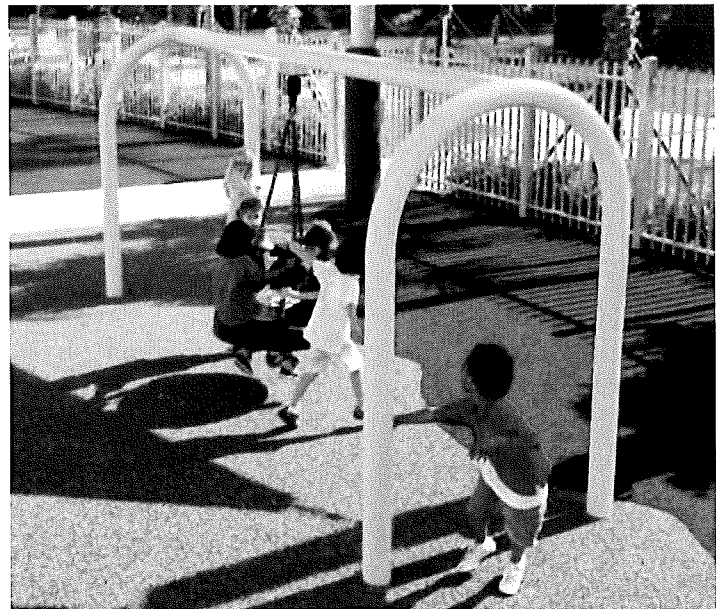
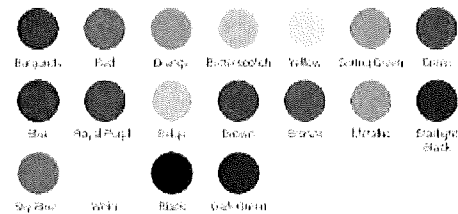

5" O.D. Oval Swing

Single \$10,590 (24'2"x25'5")

Double \$20,931 (34'11"x25'5")



2 Bay ADA Swing Set

Includes Molded Swing Seat with back and seat belt, also includes a wheelchair platform.
\$3,709



Swing Wear Mats

3' x 5' x 2' \$245 ea

135 lbs each

Beveled edges

Waffle bottom construction for stability

Red, Green, Brown, Black

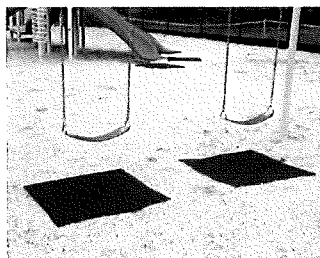

Full Bucket Swing Seats

No chains \$172

8' Galvanized chain \$223

8' Half Coated \$251

(green, blue yellow coating)

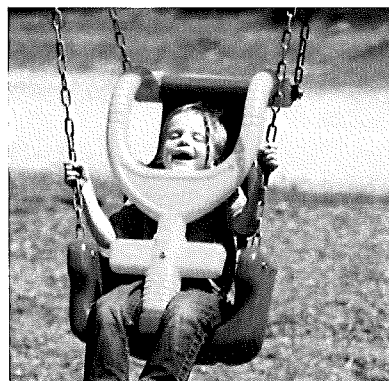
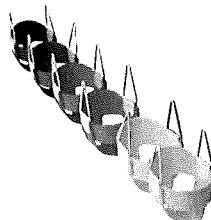

Made-For-Me Accessible Swing Seat

For kids aged 2-5 \$839

For kids aged 5-12 \$865

ADA Compliant

Seat Colors: Beige, Red, Brown, Royal Purple, Blue, Sky Blue, Green, Spring Green, or Yellow.

Chair brace in yellow only.

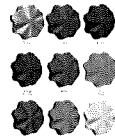

Cantilever Tot Swing

Seat

5" O.D. \$1,399

3.5" O.D. \$1,399

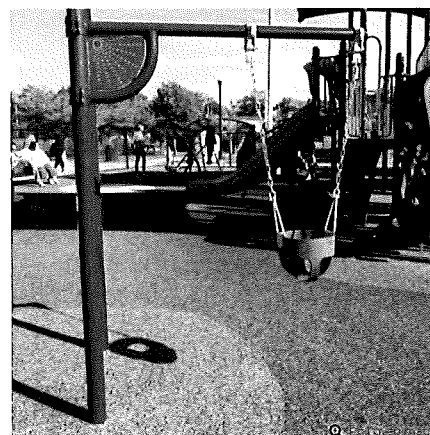
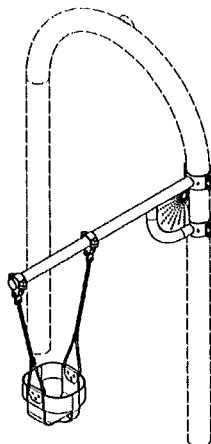

See Me Swing - Tandem Swing



6-23 month bucket seat - \$2,210
24-47 month bucket seat - \$2,210

Swing Seat Colors: black, red, green, yellow, blue, tan

Frame Fitting Colors:

Metal:

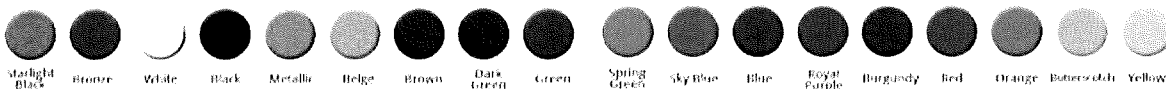

She

Play connects us

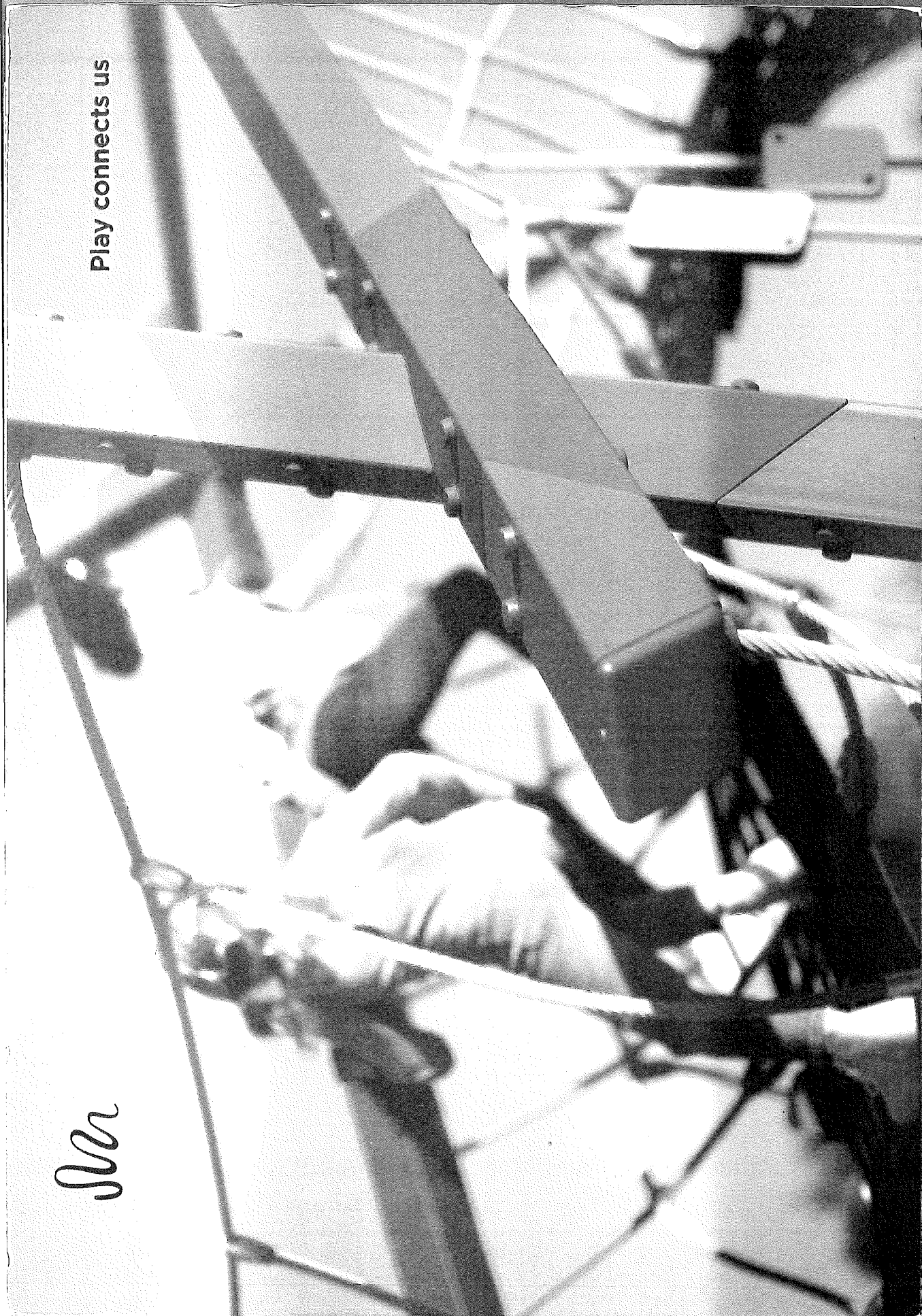

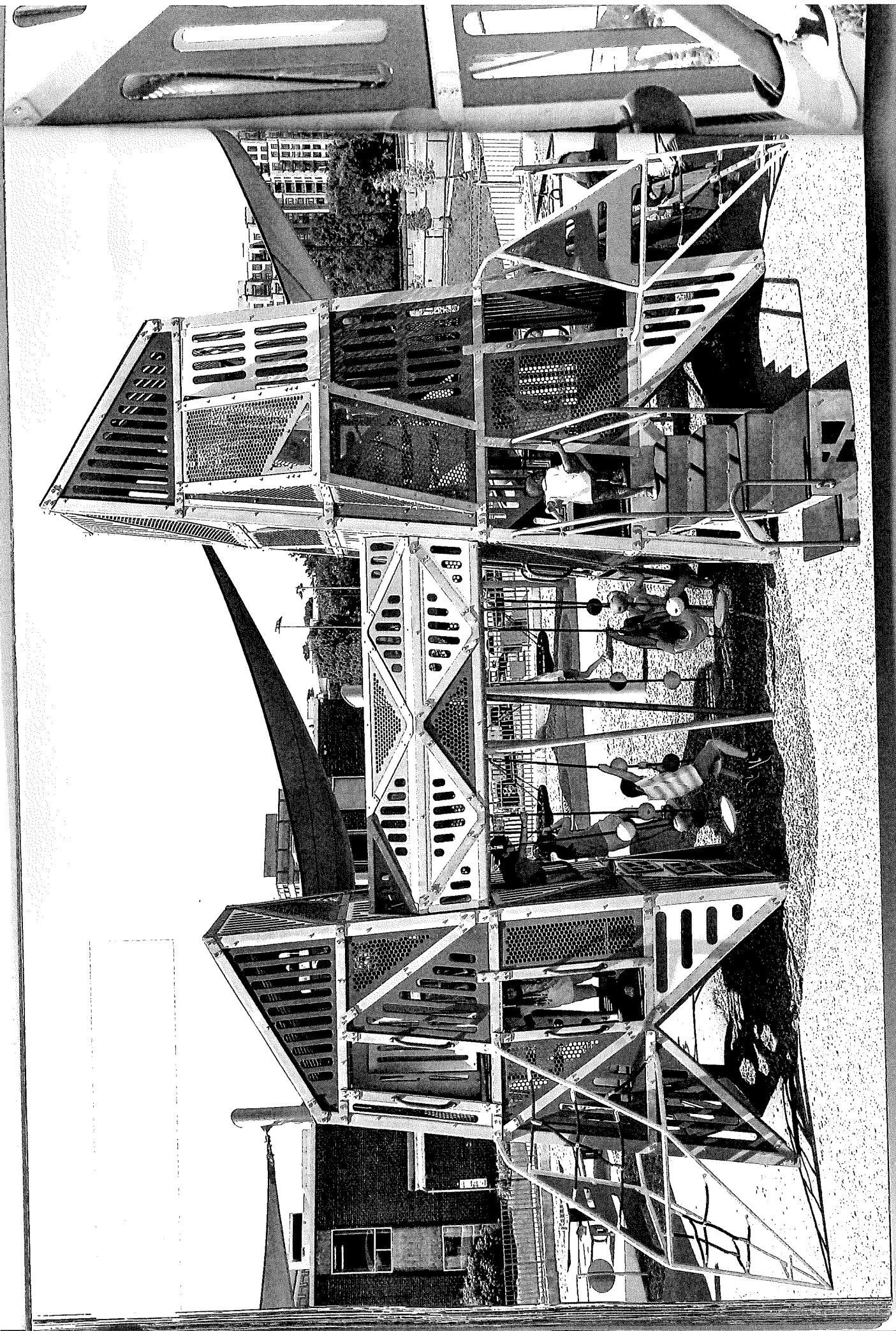

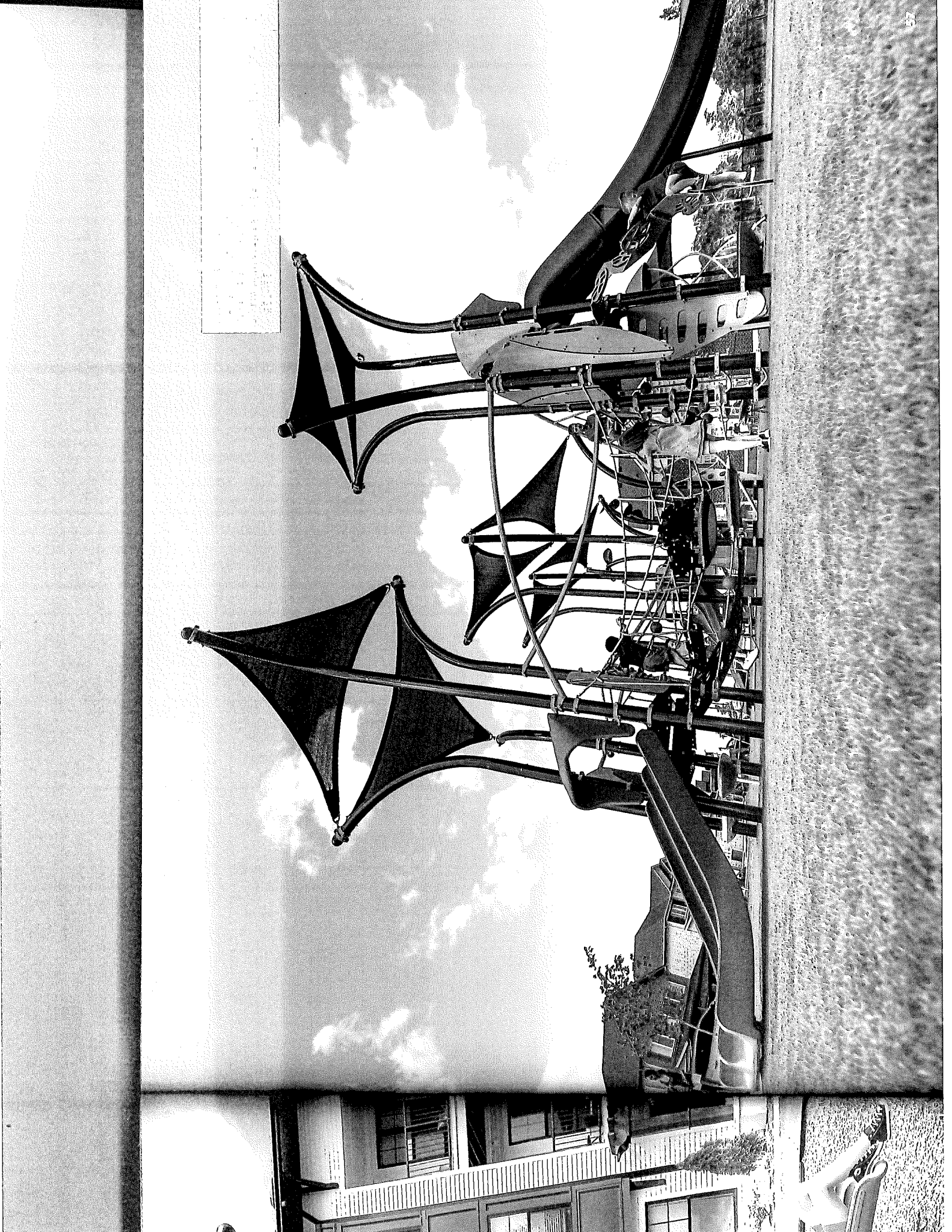

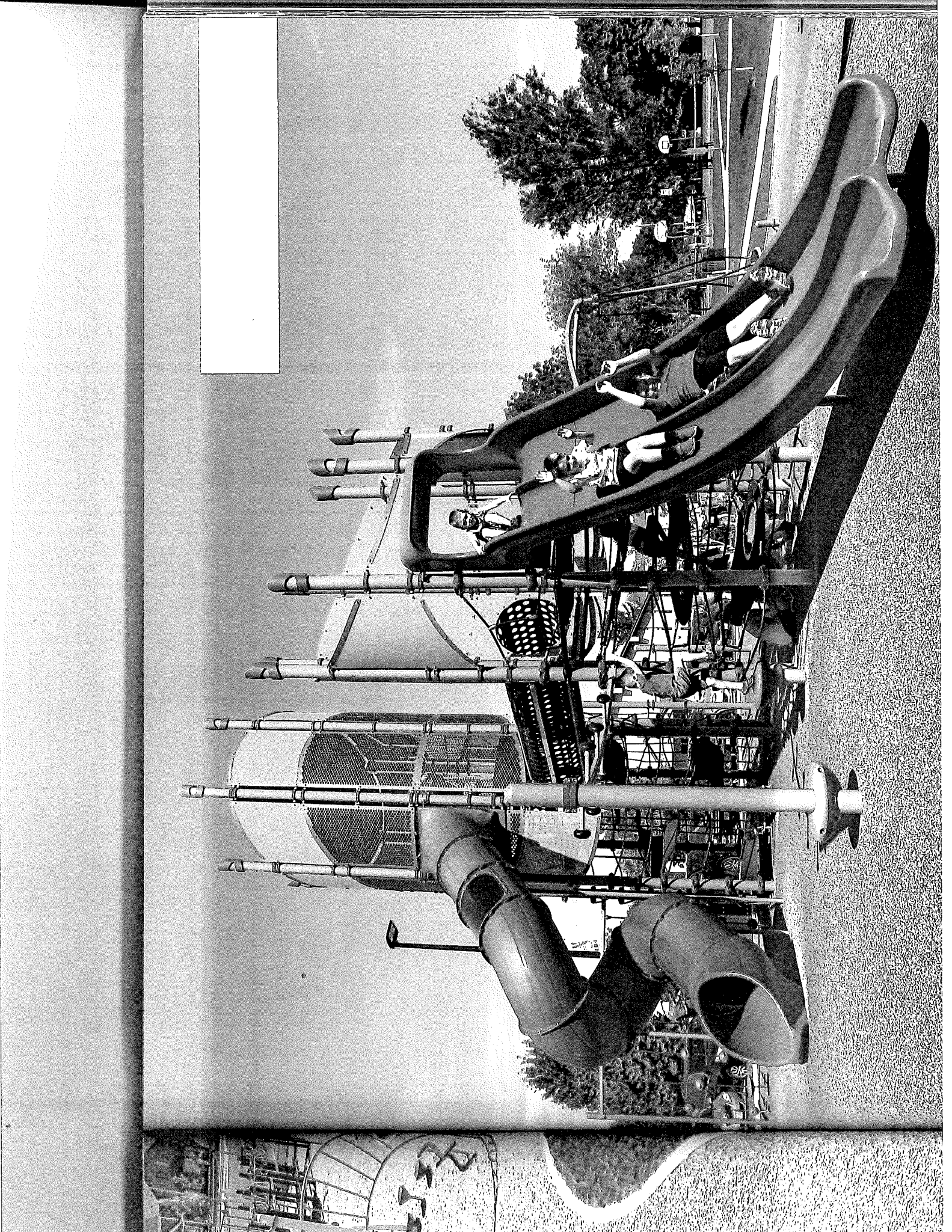

Count by Speed Range Report

Location: Main Street-Fairgrounds

Address: Main Street

Report period: 2023-04-25 to 2023-05-11

Count By Speed Range

Speed (mph)	Count
1-5	1
6-10	12
11-15	17
16-20	94
21-25	317
26-30	623
31-35	1730
36-40	2172
41-45	1724
46-50	935
51-55	305
56-60	77
61-65	15
66-70	4
71-75	0
76-80	0
81-85	0
86-90	0
91-95	0
96-100	0
Total	8026

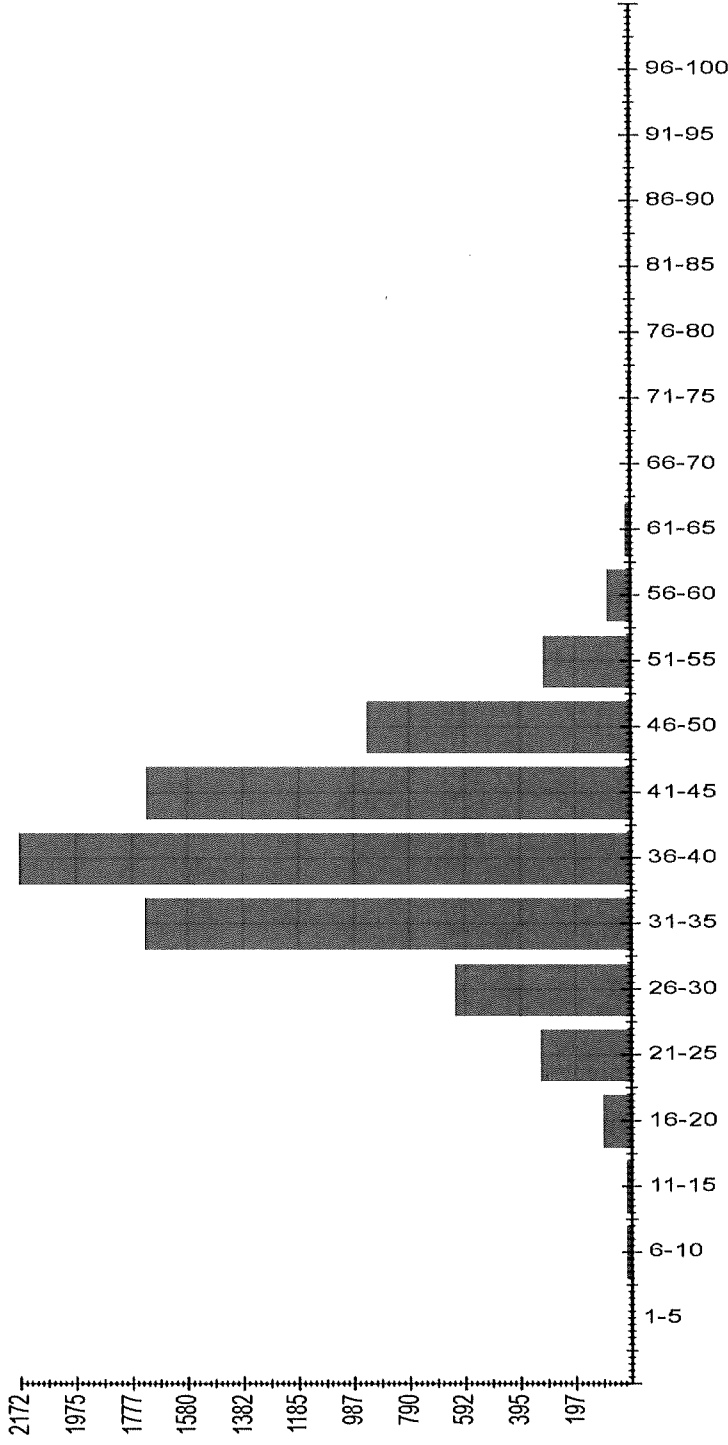

■ COUNT

Generated on May 11, 2023 at 9:10 AM

SafePace Cloud powered by Web Director®

Count by Speed Range Report

Location: Main Street-School

Address: Main Street

Report period: 2023-04-25 to 2023-05-11

Count By Speed Range

Speed (mph)	Count
1-5	28
6-10	639
11-15	990
16-20	4378
21-25	9306
26-30	2072
31-35	154
36-40	19
41-45	2
46-50	0
51-55	0
56-60	0
61-65	0
66-70	0
71-75	0
76-80	0
81-85	0
86-90	0
91-95	0
96-100	0
Total	17588

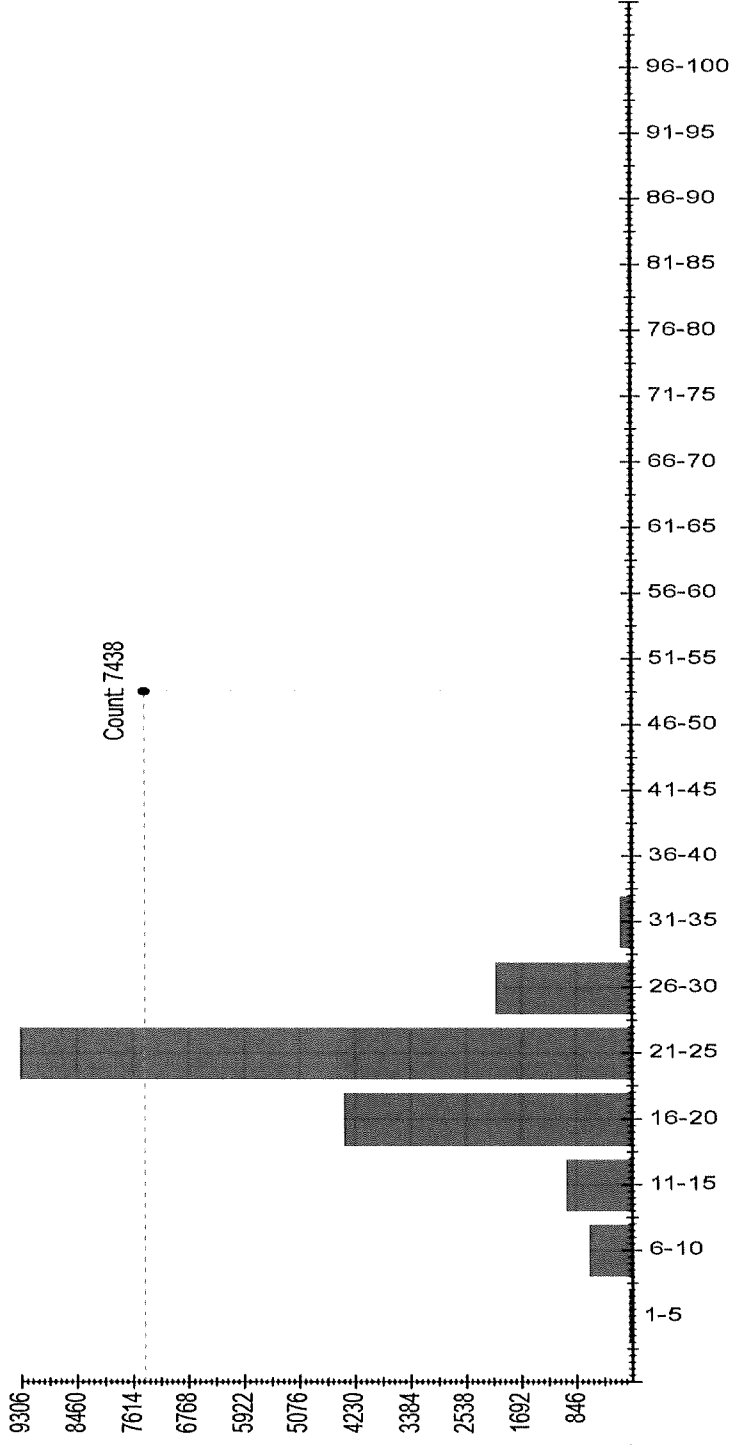

Generated on May 11, 2023 at 9:15 AM

SafePace Cloud powered by Web Director®